

A decorative graphic on the left side of the page. It features a solid blue circle at the top, a dashed circle below it, a solid light blue circle overlapping the dashed one, and several thin, curved lines that sweep across the page. A horizontal dashed line is positioned above the main text, and another is below it.

Product Manual

Barracuda

ST500DM002
ST320DM000
ST250DM000

100672652
Rev. B
August 2011

Document Revision History

Revision	Date	Description of Change
Rev. A	07/07/2011	Initial draft.
Rev. B	08/04/2011	Corrected Formatted Bytes per Sector in Table 2.2. Updated drive acoustics; updated SATA Revision to 3.0. Added base plate measurement cross reference (2.9.1). Updated Start/Stop times.

© 2011 Seagate Technology LLC. All rights reserved.

Publication number: 100672652, Rev. B August 2011

Seagate, Seagate Technology and the Wave logo are registered trademarks of Seagate Technology LLC in the United States and/or other countries. Barracuda and SeaTools are either trademarks or registered trademarks of Seagate Technology LLC or one of its affiliated companies in the United States and/or other countries. All other trademarks or registered trademarks are the property of their respective owners.

No part of this publication may be reproduced in any form without written permission of Seagate Technology LLC. Call 877-PUB-TEK1 (877-782-8351) to request permission.

One gigabyte, or GB, equals one billion bytes and one terabyte, or TB, equals one trillion bytes. Your computer's operating system may use a different standard of measurement and report a lower capacity. In addition, some of the listed capacity is used for formatting and other functions, and thus will not be available for data storage. Seagate reserves the right to change, without notice, product offerings or specifications

Contents

Seagate Technology Support Services	7
--	----------

1.0 Introduction	9
1.1 About the Serial ATA interface	9

2.0 Drive Specifications	11
2.1 Specification summary tables	11
2.2 Formatted capacity	13
2.2.1 LBA mode	13
2.3 Default logical geometry	13
2.4 Recording and interface technology	14
2.5 Physical characteristics	14
2.6 Seek time	14
2.7 Start/stop times	15
2.8 Power specifications	15
2.8.1 Power consumption	15
2.8.2 Conducted noise	16
2.8.3 Voltage tolerance	16
2.8.4 Power-management modes	16
2.9 Environmental specifications	17
2.9.1 Ambient temperature	17
2.9.2 Temperature gradient	17
2.9.3 Humidity	17
2.9.4 Altitude	17
2.9.5 Shock	17
2.9.6 Vibration	18
2.10 Acoustics	18
2.10.1 Test for Prominent Discrete Tones (PDTs)	18
2.11 Electromagnetic immunity	19
2.12 Warranty	20
2.13 Agency certification	20
2.13.1 Safety certification	20
2.13.2 Electromagnetic compatibility	20
2.13.3 FCC verification	20
2.14 Environmental protection	21
2.14.1 European Union Restriction of Hazardous Substances (RoHS) Directive	21
2.14.2 China Restriction of Hazardous Substances (RoHS) Directive	21
2.15 Corrosive environment	22

3.0 Configuring and Mounting the Drive	23
3.1 Handling and static-discharge precautions	23
3.2 Configuring the drive	23
3.3 Serial ATA cables and connectors	23
3.4 Drive mounting	24

4.0 Serial ATA (SATA) Interface	27
4.1 Hot-Plug compatibility	27
4.2 Serial ATA device plug connector pin definitions	27
4.3 Supported ATA commands	28
4.3.1 Identify Device command	31
4.3.2 Set Features command	35
4.3.3 S.M.A.R.T. commands	36

Figures

Figure 1	Attaching SATA cabling.	24
Figure 2	Mounting dimensions (500, 320 and 250 models)	25

Seagate Technology Support Services

For information regarding online support and services, visit http://www.seagate.com/www/en-us/about/contact_us/

Available services include:

- Presales & Technical support
- Global Support Services telephone numbers & business hours
- Authorized Service Centers

For information regarding Warranty Support, visit http://www.seagate.com/www/en-us/support/warranty_&_returns_assistance

For information regarding data recovery services, visit <http://www.i365.com>

For Seagate OEM and Distribution partner portal, visit <https://direct.seagate.com/portal/system>

For Seagate reseller portal, visit <http://spp.seagate.com>

1.0 Introduction

This manual describes the functional, mechanical and interface specifications for the following Seagate Barracuda® model drives:

ST500DM002

ST320DM000

ST250DM000

These drives provide the following key features:

- 7200 RPM spindle speed.
- Seagate SmartAlign™ technology provides a simple, transparent migration to Advanced Format 4K sectors.
- High instantaneous (burst) data-transfer rates (up to 600MB per second).
- Perpendicular recording technology provides the drives with increased areal density.
- State-of-the-art cache and on-the-fly error-correction algorithms.
- Native Command Queuing with command ordering to increase performance in demanding applications.
- Full-track multiple-sector transfer capability without local processor intervention.
- Quiet operation.
- Compliant with RoHS requirements in China and Europe.
- SeaTools diagnostic software performs a drive self-test that eliminates unnecessary drive returns.
- Support for S.M.A.R.T. drive monitoring and reporting.
- Supports latching SATA cables and connectors.
- Worldwide Name (WWN) capability uniquely identifies the drive.

1.1 About the Serial ATA interface

The Serial ATA interface provides several advantages over the traditional (parallel) ATA interface. The primary advantages include:

- Easy installation and configuration with true plug-and-play connectivity. It is not necessary to set any jumpers or other configuration options.
- Thinner and more flexible cabling for improved enclosure airflow and ease of installation.
- Scalability to higher performance levels.

In addition, Serial ATA makes the transition from parallel ATA easy by providing legacy software support. Serial ATA was designed to allow you to install a Serial ATA host adapter and Serial ATA disk drive in your current system and expect all of your existing applications to work as normal.

The Serial ATA interface connects each disk drive in a point-to-point configuration with the Serial ATA host adapter. There is no master/slave relationship with Serial ATA devices like there is with parallel ATA. If two drives are attached on one Serial ATA host adapter, the host operating system views the two devices as if they were both “masters” on two separate ports. This essentially means both drives behave as if they are Device 0 (master) devices.

Note

The host adapter may, optionally, emulate a master/slave environment to host software where two devices on separate Serial ATA ports are represented to host software as a Device 0 (master) and Device 1 (slave) accessed at the same set of host bus addresses. A host adapter that emulates a master/slave environment manages two sets of shadow registers. This is not a typical Serial ATA environment.

The Serial ATA host adapter and drive share the function of emulating parallel ATA device behavior to provide backward compatibility with existing host systems and software. The Command and Control Block registers, PIO and DMA data transfers, resets, and interrupts are all emulated.

The Serial ATA host adapter contains a set of registers that shadow the contents of the traditional device registers, referred to as the Shadow Register Block. All Serial ATA devices behave like Device 0 devices. For additional information about how Serial ATA emulates parallel ATA, refer to the “Serial ATA International Organization: Serial ATA Revision 3.0”. The specification can be downloaded from www.sata-io.org.

2.0 Drive Specifications

Unless otherwise noted, all specifications are measured under ambient conditions, at 25°C, and nominal power. For convenience, the phrases *the drive* and *this drive* are used throughout this manual to indicate the following drive models:

ST500DM002

ST320DM000

ST250DM000

2.1 Specification summary tables

The specifications listed in the following tables are for quick reference. For details on specification measurement or definition, see the appropriate section of this manual.

Table 1 Drive specifications summary for 500, 320 and 250GB models

Drive Specification*	ST500DM002	ST320DM000	ST250DM000
Formatted capacity**	500GB	320GB	250GB
Guaranteed sectors	976,773,168	625,142,448	488,397,168
Heads	2	2	1
Disks	1	1	1
Bytes per sector	4096	4096	4096
Default sectors per track	63	63	63
Default read/write heads	16	16	16
Default cylinders	16,383	16,383	16,383
Recording density (max.)	1413kb/in	1413kb/in	1413kb/in
Track density (avg.)	236 ktracks/in	236 ktracks/in	236 ktracks/in
Areal density (avg.)	329Gb/in ²	329Gb/in ²	329Gb/in ²
Spindle speed	7200 RPM	7200 RPM	7200 RPM
Internal data transfer rate (max)	1695Mb/s	1695Mb/s	1695Mb/s
Sustained data transfer rate OD (max)	125MB/s	125MB/s	125MB/s
I/O data-transfer rate (max.)	600MB/s	600MB/s	600MB/s
Cache buffer	16MB	16MB	16MB
Height (max)	19.98mm / 0.787 in	19.98mm / 0.787 in	19.98mm / 0.787 in
Width (max)	101.6mm / 4.0 in (± 0.010 in)	101.6mm / 4.0 in (± 0.010 in)	101.6mm / 4.0 in (± 0.010 in)
Length (max)	146.99mm / 5.787 in	146.99mm / 5.787 in	146.99mm / 5.787 in
Weight (typical)	415g / 0.915 lb	415g / 0.915 lb	415g / 0.915 lb
Average latency	4.16ms	4.16ms	4.16ms
Power-on to ready (max)	<8.5s	<8.5s	<8.5s
Standby to ready (max)	<8.5s	<8.5s	<8.5s
Track-to-track seek time (typical)	<1.0ms read; <1.2ms write	<1.0ms read; <1.2ms write	<1.0ms (read) <1.2ms (write)
Average seek, read (typical)	<8.5ms (read)	<8.5ms (read)	<8.5ms (read)
Average seek, write (typical)	<9.5ms (write)	<9.5ms (write)	<9.5ms (write)
Startup current (typical) 12V (peak)	2.0A	2.0A	2.0A

Table 1 Drive specifications summary for 500, 320 and 250GB models (continued)

Drive Specification*	ST500DM002	ST320DM000	ST250DM000
Voltage tolerance (including noise)	5V ±5% 12V +10% / -7.5%	5V ±5% 12V +10% / -7.5%	5V ±5% 12V +10% / -7.5%
Ambient temperature	0° to 60°C (operating) -40° to 70°C (non-operating)	0° to 60°C (operating) -40° to 70°C (non-operating)	0° to 60°C (operating) -40° to 70°C (non-operating)
Temperature gradient	20°C per hour max (operating) 30°C per hour max (non-operating)	20°C per hour max (operating) 30°C per hour max (non-operating)	20°C per hour max (operating) 30°C per hour max (non-operating)
Relative humidity	5% to 95% (operating) 5% to 95% (non-operating)	5% to 95% (operating) 5% to 95% (non-operating)	5% to 95% (operating) 5% to 95% (non-operating)
Relative humidity gradient (max)	30% per hour	30% per hour	30% per hour
Wet bulb temperature (max)	37.7°C (operating) 40.0°C (non-operating)	37.7°C (operating) 40.0°C (non-operating)	37.7°C (operating) 40.0°C (non-operating)
Altitude, operating	-304.8m to 3,048m (-1000 ft to 10,000+ ft)	-304.8m to 3,048m (-1000 ft to 10,000+ ft)	-304.8m to 3,048m (-1000 ft to 10,000+ ft)
Altitude, non-operating (below mean sea level, max)	-304.8m to 12,192m (-1000 ft to 40,000+ ft)	-304.8m to 12,192m (-1000 ft to 40,000+ ft)	-304.8m to 12,192m (-1000 ft to 40,000+ ft)
Operational Shock (max)	70 Gs at 2ms	70 Gs at 2ms	70 Gs at 2ms
Non-Operational Shock (max)	350 Gs at 2ms	350 Gs at 2ms	350 Gs at 2ms
Vibration, operating	2Hz to 22Hz: 0.25 Gs, Limited displacement 22Hz to 350Hz: 0.50 Gs 350Hz to 500Hz: 0.25 Gs		
Vibration, non-operating	5Hz to 22Hz: 3.0 Gs 22Hz to 350Hz: 3.0 Gs 350Hz to 500Hz: 3.0 Gs		
Drive acoustics, sound power			
Idle***	2.2 bels (typical) 2.3 bels (max)	2.2 bels (typical) 2.3 bels (max)	2.2 bels (typical) 2.3 bels (max)
Seek	2.3 bels (typical) 2.4 bels (max)	2.3 bels (typical) 2.4 bels (max)	2.3 bels (typical) 2.4 bels (max)
Non-recoverable read errors	1 per 10 ¹⁴ bits read	1 per 10 ¹⁴ bits read	1 per 10 ¹⁴ bits read
Warranty	To determine the warranty for a specific drive, use a web browser to access the following web page: support.seagate.com/customer/warranty_validation.jsp From this page, click on the "Verify Your Warranty" link. You will be asked to provide the drive serial number, model number (or part number) and country of purchase. The system will display the warranty information for your drive.		
Contact start-stop cycles	50,000 at 25°C, 50% rel. humidity	50,000 at 25°C, 50% rel. humidity	50,000 at 25°C, 50% rel. humidity
Supports Hotplug operation per the Serial ATA Revision 3.0 specification	Yes	Yes	Yes

* All specifications values based on native capacity configuration.

**One GB equals one billion bytes when referring to hard drive capacity. Accessible capacity may vary depending on operating environment and formatting.

***During periods of drive idle, some offline activity may occur according to the S.M.A.R.T. specification, which may increase acoustic and power to operational levels.

2.2 Formatted capacity

Model	Formatted capacity*	Guaranteed sectors	Bytes per sector
ST500DM002	500GB	976,773,168	4K
ST320DM000	320GB	625,142,448	
ST250DM000	250GB	488,397,168	

*One GB equals one billion bytes when referring to hard drive capacity. Accessible capacity may vary depending on operating environment and formatting.

2.2.1 LBA mode

When addressing these drives in LBA mode, all blocks (sectors) are consecutively numbered from 0 to $n-1$, where n is the number of guaranteed sectors as defined above.

See Section 4.3.1, "Identify Device command" (words 60-61 and 100-103) for additional information about 48-bit addressing support of drives with capacities over 137GB.

2.3 Default logical geometry

Cylinders	Read/write heads	Sectors per track
16,383	16	63

LBA mode

When addressing these drives in LBA mode, all blocks (sectors) are consecutively numbered from 0 to $n-1$, where n is the number of guaranteed sectors as defined above.

2.4 Recording and interface technology

Interface	Serial ATA (SATA)
Recording method	Perpendicular
Recording density (kbits/inch max)	1413
Track density (ktracks/inch avg)	236
Areal density (Gbits/inch ² avg)	329
Spindle speed (RPM)	7,200 ± 0.2%
Internal data transfer rate (Mb/s max)	1695
Sustained data transfer rate (MB/s max)	125
I/O data-transfer rate (MB/s max)	600

2.5 Physical characteristics

Maximum height 500, 320 and 250GB models	19.98mm / 0.787 in
Maximum width	101.6mm / 4.000 (± 0.010 in)
Maximum length	146.99mm / 5.787 in
Typical weight 500, 320 and 250GB models	415g / 0.915 lb
Cache buffer 500, 320 and 250GB models	16MB (16,384kb)

2.6 Seek time

Seek measurements are taken with nominal power at 25°C ambient temperature. All times are measured using drive diagnostics. The specifications in the table below are defined as follows:

- Track-to-track seek time is an average of all possible single-track seeks in both directions.
- Average seek time is a true statistical random average of at least 5,000 measurements of seeks between random tracks, less overhead.

Typical seek times (ms)	Read	Write
Track-to-track	1.0	1.2
Average	8.5	9.5
Average latency	4.16	

Note

These drives are designed to consistently meet the seek times represented in this manual. Physical seeks, regardless of mode (such as track-to-track and average), are expected to meet the noted values. However, due to the manner in which these drives are formatted, benchmark tests that include command overhead or measure logical seeks may produce results that vary from these specifications.

2.7 Start/stop times

Start/stop times for all models are listed below.

Power-on to Ready (typ / max sec)	8.5 / 10
Standby to Ready (typ / max sec)	8.5 / 10
Ready to spindle stop (typ / max sec)	10 / 12

Time-to-ready may be longer than normal if the drive power is removed without going through normal OS power-down procedures.

2.8 Power specifications

The drive receives DC power (+5V or +12V) through a native SATA power connector. Refer to [Section Figure 1 on page 24](#) on page 24.

2.8.1 Power consumption

Power requirements for the drives are listed in [Section Table 2 on page 15](#). Typical power measurements are based on an average of drives tested, under nominal conditions, using 5.0V and 12.0V input voltage at 25°C ambient temperature.

- Spinup power
Spinup power is measured from the time of power-on to the time that the drive spindle reaches operating speed.
- Read/write power and current
Read/write power is measured with the heads on track, based on a 16-sector write followed by a 32-ms delay, then a 16-sector read followed by a 32-ms delay.
- Operating power and current
Operating power is measured using 40 percent random seeks, 40 percent read/write mode (1 write for each 10 reads) and 20 percent drive idle mode.
- Idle mode power
Idle mode power is measured with the drive up to speed, with servo electronics active and with the heads in a random track location.
- Standby mode
During Standby mode, the drive accepts commands, but the drive is not spinning, and the servo and read/write electronics are in power-down mode.

Table 2 DC power requirements (1-disk)

Power dissipation (1-disk values shown)	Avg (watts 25° C)	Avg 5V typ amps	Avg 12V typ amps
Spinup	—	—	2.0 (peak)
Idle* †	4.60	0.378	0.224
Idle* † (with offline activity)	4.50	0.250	0.240
Operating	6.19	0.656	0.243
Standby	0.79	0.35	0.01
Sleep	0.79	0.35	0.01

*During periods of drive idle, some offline activity may occur according to the S.M.A.R.T. specification, which may increase acoustic and power to operational levels.

†5W IDLE with DIPLM Enabled

2.8.2 Conducted noise

Input noise ripple is measured at the host system power supply across an equivalent 80-ohm resistive load on the +12 volt line or an equivalent 15-ohm resistive load on the +5 volt line.

- Using 12-volt power, the drive is expected to operate with a maximum of 120 mV peak-to-peak square-wave injected noise at up to 10MHz.
- Using 5-volt power, the drive is expected to operate with a maximum of 100 mV peak-to-peak square-wave injected noise at up to 10MHz.

Note

Equivalent resistance is calculated by dividing the nominal voltage by the typical RMS read/write current.

2.8.3 Voltage tolerance

Voltage tolerance (including noise):

- 5V: $\pm 5\%$
- 12V: +10% / -7.5%

2.8.4 Power-management modes

The drive provides programmable power management to provide greater energy efficiency. In most systems, you can control power management through the system setup program. The drive features the following power-management modes:

Power modes	Heads	Spindle	Buffer
Active	Tracking	Rotating	Enabled
Idle	Tracking	Rotating	Enabled
Standby	Parked	Stopped	Enabled
Sleep	Parked	Stopped	Disabled

- **Active mode**
The drive is in Active mode during the read/write and seek operations.
- **Idle mode**
The buffer remains enabled, and the drive accepts all commands and returns to Active mode any time disk access is necessary.
- **Standby mode**
The drive enters Standby mode when the host sends a Standby Immediate command. If the host has set the standby timer, the drive can also enter Standby mode automatically after the drive has been inactive for a specifiable length of time. The standby timer delay is established using a Standby or Idle command. In Standby mode, the drive buffer is enabled, the heads are parked and the spindle is at rest. The drive accepts all commands and returns to Active mode any time disk access is necessary.
- **Sleep mode**
The drive enters Sleep mode after receiving a Sleep command from the host. In Sleep mode, the drive buffer is disabled, the heads are parked and the spindle is at rest. The drive leaves Sleep mode after it receives a Hard Reset or Soft Reset from the host. After receiving a reset, the drive exits Sleep mode and enters Standby mode with all current translation parameters intact.
- **Idle and Standby timers**
Each time the drive performs an Active function (read, write or seek), the standby timer is reinitialized and begins counting down from its specified delay times to zero. If the standby timer reaches zero before any drive activity is required, the drive makes a transition to Standby mode. In both Idle and Standby mode, the drive accepts all commands and returns to Active mode when disk access is necessary.

2.9 Environmental specifications

2.9.1 Ambient temperature

Ambient temperature is defined as the temperature of the environment immediately surrounding the drive. Actual drive case temperature should not exceed 69°C (156°F) within the operating ambient conditions. Refer to [Section 3.4 on page 24](#) for base plate measurement location.

Operating:	0° to 60°C (32° to 140°F)
Non-operating:	-40° to 70°C (-40° to 158°F)

2.9.2 Temperature gradient

Operating:	20°C per hour (68°F per hour max), without condensation
Non-operating:	30°C per hour (86°F per hour max)

2.9.3 Humidity

2.9.3.1 Relative humidity

Operating:	5% to 95% non-condensing (30% per hour max)
Nonoperating:	5% to 95% non-condensing (30% per hour max)

2.9.3.2 Wet bulb temperature

Operating:	37.7°C (99.9°F max)
Non-operating:	40°C (104°F max)

2.9.4 Altitude

Operating:	-304.8 m to 3,048 m (-1000 ft. to 10,000+ ft.)
Non-operating:	-304.8 m to 12,192 m (-1000 ft. to 40,000+ ft.)

2.9.5 Shock

All shock specifications assume that the drive is mounted securely with the input shock applied at the drive mounting screws. Shock may be applied in the X, Y or Z axis.

2.9.5.1 Operating shock

These drives comply with the performance levels specified in this document when subjected to a maximum operating shock of 70 Gs based on half-sine shock pulses of 2 ms during read operations. Shocks should not be repeated more than two times per second.

2.9.5.2 Non-operating shock

500, 320, and 250GB models

The non-operating shock level that the drive can experience without incurring physical damage or degradation in performance when subsequently put into operation is 350 Gs based on a non-repetitive half-sine shock pulse of 2-ms duration.

2.9.6 Vibration

All vibration specifications assume that the drive is mounted securely with the input vibration applied at the drive mounting screws. Vibration may be applied in the X, Y or Z axis.

2.9.6.1 Operating vibration

The maximum vibration levels that the drive may experience while meeting the performance standards specified in this document are specified below.

2Hz to 22Hz	0.25 Gs (Limited displacement)
22Hz to 350Hz	0.50 Gs
350Hz to 500Hz	0.25 Gs

2.9.6.2 Non-operating vibration

The maximum non-operating vibration levels that the drive may experience without incurring physical damage or degradation in performance when subsequently put into operation are specified below.

5Hz to 22Hz	3.0 Gs (Limited displacement)
22Hz to 350Hz	3.0 Gs
350Hz to 500Hz	3.0 Gs

2.10 Acoustics

Drive acoustics are measured as overall A-weighted acoustic sound power levels (no pure tones). All measurements are consistent with ISO document 7779. Sound power measurements are taken under essentially free-field conditions over a reflecting plane. For all tests, the drive is oriented with the cover facing upward.

Note	For seek mode tests, the drive is placed in seek mode only. The number of seeks per second is defined by the following equation: (Number of seeks per second = 0.4 / (average latency + average access time))
-------------	--

Table 3 Fluid Dynamic Bearing (FDB) motor acoustics

	Idle*	Seek
500, 320 and 250GB models	2.2 bels (typ) 2.3 bels (max)	2.3 bels (typ) 2.4 bels (max)

*During periods of drive idle, some offline activity may occur according to the S.M.A.R.T. specification, which may increase acoustic and power to operational levels.

2.10.1 Test for Prominent Discrete Tones (PDTs)

Seagate follows the ECMA-74 standards for measurement and identification of PDTs. An exception to this process is the use of the absolute threshold of hearing. Seagate uses this threshold curve (originated in ISO 389-7) to discern tone audibility and to compensate for the inaudible components of sound prior to computation of tone ratios according to Annex D of the ECMA-74 standards.

2.11 Electromagnetic immunity

When properly installed in a representative host system, the drive operates without errors or degradation in performance when subjected to the radio frequency (RF) environments defined in the following [Table 4](#):

Table 4 *Radio frequency environments*

Test	Description	Performance level	Reference standard
Electrostatic discharge	Contact, HCP, VCP: ± 4 kV; Air: ± 8 kV	B	EN61000-4-2: 95
Radiated RF immunity	80MHz to 1,000MHz, 3 V/m, 80% AM with 1kHz sine 900MHz, 3 V/m, 50% pulse modulation @ 200Hz	A	EN61000-4-3: 96 ENV50204: 95
Electrical fast transient	± 1 kV on AC mains, ± 0.5 kV on external I/O	B	EN61000-4-4: 95
Surge immunity	± 1 kV differential, ± 2 kV common, AC mains	B	EN61000-4-5: 95
Conducted RF immunity	150kHz to 80MHz, 3 Vrms, 80% AM with 1kHz sine	A	EN61000-4-6: 97
Voltage dips, interrupts	0% open, 5 seconds 0% short, 5 seconds 40%, 0.10 seconds 70%, 0.01 seconds	C C C B	EN61000-4-11: 94

2.12 Warranty

To determine the warranty for a specific drive, use a web browser to access the following web page:
support.seagate.com/customer/warranty_validation.jsp

From this page, click on the “Verify Your Warranty” link. You will be asked to provide the drive serial number, model number (or part number) and country of purchase. The system will display the warranty information for your drive.

2.13 Agency certification

2.13.1 Safety certification

These products are certified to meet the requirements of UL60950-1, CSA60950-1 and EN60950 and so marked as to the certify agency.

2.13.2 Electromagnetic compatibility

Hard drives that display the CE mark comply with the European Union (EU) requirements specified in the Electromagnetic Compatibility Directive (2004/108/EC) as put into place 20 July 2007. Testing is performed to the levels specified by the product standards for Information Technology Equipment (ITE). Emission levels are defined by EN 55022, Class B and the immunity levels are defined by EN 55024.

Drives are tested in representative end-user systems. Although CE-marked Seagate drives comply with the directives when used in the test systems, we cannot guarantee that all systems will comply with the directives. The drive is designed for operation inside a properly designed enclosure, with properly shielded I/O cable (if necessary) and terminators on all unused I/O ports. Computer manufacturers and system integrators should confirm EMC compliance and provide CE marking for their products.

Korean RRL

If these drives have the Korean Communications Commission (KCC) logo, they comply with paragraph 1 of Article 11 of the Electromagnetic Compatibility control Regulation and meet the Electromagnetic Compatibility (EMC) Framework requirements of the Radio Research Laboratory (RRL) Communications Commission, Republic of Korea.

These drives have been tested and comply with the Electromagnetic Interference/Electromagnetic Susceptibility (EMI/EMS) for Class B products. Drives are tested in a representative, end-user system by a Korean-recognized lab.

- Family name: Barracuda 7200.12
- Certificate number: STX - 720012 (B)

Australian C-Tick (N176)

If these models have the C-Tick marking, they comply with the Australia/New Zealand Standard AS/NZ CISPR22 and meet the Electromagnetic Compatibility (EMC) Framework requirements of the Australian Communication Authority (ACA).

2.13.3 FCC verification

These drives are intended to be contained solely within a personal computer or similar enclosure (not attached as an external device). As such, each drive is considered to be a subassembly even when it is individually marketed to the customer. As a subassembly, no Federal Communications Commission verification or certification of the device is required.

Seagate has tested this device in enclosures as described above to ensure that the total assembly (enclosure, disk drive, motherboard, power supply, etc.) does comply with the limits for a Class B computing device, pursuant to Subpart J, Part 15 of the FCC rules. Operation with non-certified assemblies is likely to result in interference to radio and television reception.

Radio and television interference. This equipment generates and uses radio frequency energy and if not installed and used in strict accordance with the manufacturer’s instructions, may cause interference to radio and television reception.

This equipment is designed to provide reasonable protection against such interference in a residential installation. However, there is no guarantee that interference will not occur in a particular installation. If this equipment does cause interference to radio or television, which can be determined by turning the equipment on and off, you are encouraged to try one or more of the following corrective measures:

- Reorient the receiving antenna.
- Move the device to one side or the other of the radio or TV.
- Move the device farther away from the radio or TV.
- Plug the computer into a different outlet so that the receiver and computer are on different branch outlets.

If necessary, you should consult your dealer or an experienced radio/television technician for additional suggestions. You may find helpful the following booklet prepared by the Federal Communications Commission: *How to Identify and Resolve Radio-Television Interference Problems*. This booklet is available from the Superintendent of Documents, U.S. Government Printing Office, Washington, DC 20402. Refer to publication number 004-000-00345-4.

2.14 Environmental protection

Seagate designs its products to meet environmental protection requirements worldwide, including regulations restricting certain chemical substances.

2.14.1 European Union Restriction of Hazardous Substances (RoHS) Directive

The European Union Restriction of Hazardous Substances (RoHS) Directive, restricts the presence of chemical substances, including Lead, Cadmium, Mercury, Hexavalent Chromium, PBB and PBDE, in electronic products, effective July 2006. This drive is manufactured with components and materials that comply with the RoHS Directive.

2.14.2 China Restriction of Hazardous Substances (RoHS) Directive 中国限制危险物品的指令

This product has an Environmental Protection Use Period (EPUP) of 20 years. The following table contains information mandated by China's "Marking Requirements for Control of Pollution Caused by Electronic Information Products" Standard.



该产品具有20年的环境保护使用周期（EPUP）。下表包含了中国“电子产品所导致的污染的控制的记号要求”所指定的信息。

Name of Parts 部件名称	Toxic or Hazardous Substances or Elements有毒有害物质或元素					
	Lead 铅 (Pb)	Mercury 汞 (Hg)	Cadmium 镉 (Cd)	Hexavalent Chromium 六价铬 (Cr6+)	Polybrominated Diphenyl 多溴联苯 (PBB)	Polybrominated Diphenyl Ether 多溴二苯醚 (PBDE)
PCBA	X	O	O	O	O	O
HDA	X	O	O	O	O	O

"O" indicates the hazardous and toxic substance content of the part (at the homogenous material level) is lower than the threshold defined by the China RoHS MCV Standard.

“O”表示该部件（于同类物品程度上）所含的危险和有毒物质低于中国RoHS MCV标准所定义的门槛值。

"X" indicates the hazardous and toxic substance content of the part (at the homogenous material level) is over the threshold defined by the China RoHS MCV Standard.

“X”表示该部件（于同类物品程度上）所含的危险和有毒物质超出中国RoHS MCV标准所定义的门槛值。

2.15 Corrosive environment

Seagate electronic drive components pass accelerated corrosion testing equivalent to 10 years exposure to light industrial environments containing sulfurous gases, chlorine and nitric oxide, classes G and H per ASTM B845. However, this accelerated testing cannot duplicate every potential application environment. Users should use caution exposing any electronic components to uncontrolled chemical pollutants and corrosive chemicals as electronic drive component reliability can be affected by the installation environment. The silver, copper, nickel and gold films used in Seagate products are especially sensitive to the presence of sulfide, chloride, and nitrate contaminants. Sulfur is found to be the most damaging. In addition, electronic components should never be exposed to condensing water on the surface of the printed circuit board assembly (PCBA) or exposed to an ambient relative humidity greater than 95%. Materials used in cabinet fabrication, such as vulcanized rubber, that can outgas corrosive compounds should be minimized or eliminated. The useful life of any electronic equipment may be extended by replacing materials near circuitry with sulfide-free alternatives.

3.0 Configuring and Mounting the Drive

This section contains the specifications and instructions for configuring and mounting the drive.

3.1 Handling and static-discharge precautions

After unpacking, and before installation, the drive may be exposed to potential handling and electrostatic discharge (ESD) hazards. Observe the following standard handling and static-discharge precautions:

Caution

- Before handling the drive, put on a grounded wrist strap, or ground yourself frequently by touching the metal chassis of a computer that is plugged into a grounded outlet. Wear a grounded wrist strap throughout the entire installation procedure.
- Handle the drive by its edges or frame *only*.
- The drive is extremely fragile—handle it with care. Do not press down on the drive top cover.
- Always rest the drive on a padded, antistatic surface until you mount it in the computer.
- Do not touch the connector pins or the printed circuit board.
- Do not remove the factory-installed labels from the drive or cover them with additional labels. Removal voids the warranty. Some factory-installed labels contain information needed to service the drive. Other labels are used to seal out dirt and contamination.

3.2 Configuring the drive

Each drive on the Serial ATA interface connects point-to-point with the Serial ATA host adapter. There is no master/slave relationship because each drive is considered a master in a point-to-point relationship. If two drives are attached on one Serial ATA host adapter, the host operating system views the two devices as if they were both “masters” on two separate ports. Both drives behave as if they are Device 0 (master) devices.

Serial ATA drives are designed for easy installation. It is usually not necessary to set any jumpers on the drive for proper operation; however, if you connect the drive and receive a “drive not detected” error, your SATA-equipped motherboard or host adapter may use a chipset that does not support SATA speed autonegotiation.

3.3 Serial ATA cables and connectors

The Serial ATA interface cable consists of four conductors in two differential pairs, plus three ground connections. The cable size may be 30 to 26 AWG with a maximum length of one meter (39.37 inches). See [Table 5](#) for connector pin definitions. Either end of the SATA signal cable can be attached to the drive or host.

For direct backplane connection, the drive connectors are inserted directly into the host receptacle. The drive and the host receptacle incorporate features that enable the direct connection to be hot pluggable and blind mateable.

For installations which require cables, you can connect the drive as illustrated in [Figure 1](#).

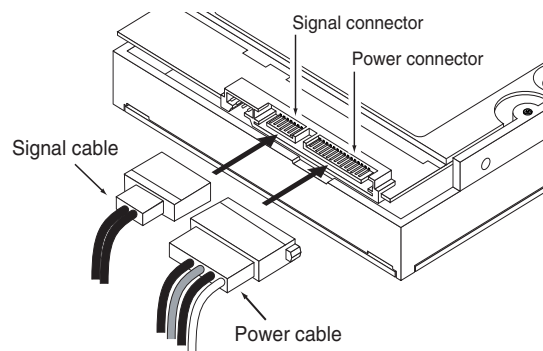
Figure 1 Attaching SATA cabling

Each cable is keyed to ensure correct orientation. Barracuda drives support latching SATA connectors.

3.4 Drive mounting

You can mount the drive in any orientation using four screws in the side-mounting holes or four screws in the bottom-mounting holes. See [Figure 2](#) for drive mounting dimensions. Follow these important mounting precautions when mounting the drive:

- Allow a minimum clearance of 0.030 inches (0.76mm) around the entire perimeter of the drive for cooling.
- Use only 6-32 UNC mounting screws.
- The screws should be inserted no more than 0.150 inch (3.81mm) into the bottom or side mounting holes.
- Do not overtighten the mounting screws (maximum torque: 6 inch-lb).

Figure 2 Mounting dimensions (500, 320 and 250 models)

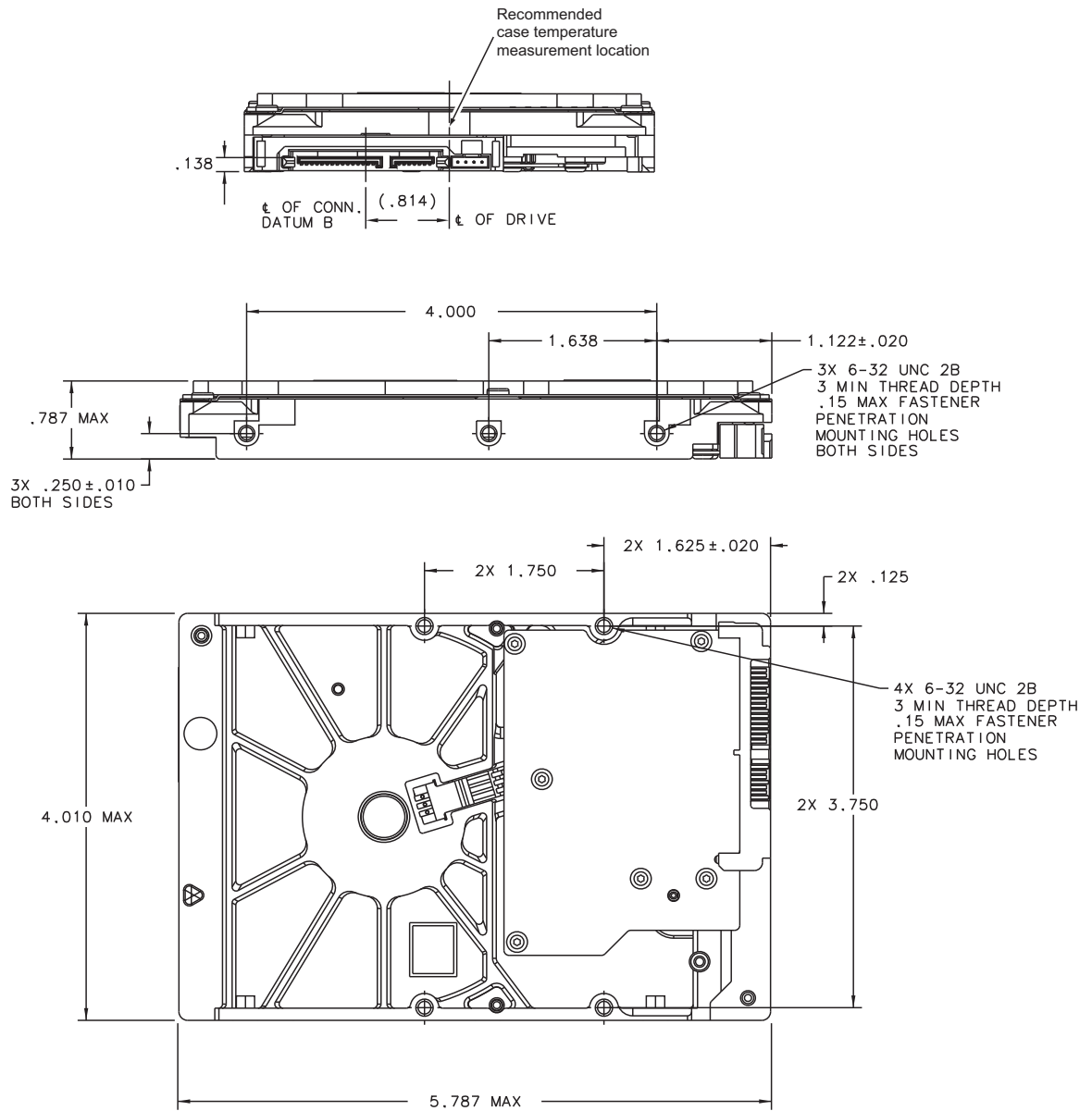

4.0 Serial ATA (SATA) Interface

These drives use the industry-standard Serial ATA interface that supports FIS data transfers. It supports ATA programmed input/output (PIO) modes 0 to 4; multiword DMA modes 0 to 2, and Ultra DMA modes 0 to 6.

For detailed information about the Serial ATA interface, refer to the “Serial ATA: High Speed Serialized AT Attachment” specification.

4.1 Hot-Plug compatibility

Barracuda drives incorporate connectors which enable you to hot plug these drives in accordance with the Serial ATA Revision 3.0 specification. This specification can be downloaded from www.serialata.org.

4.2 Serial ATA device plug connector pin definitions

Table 5 summarizes the signals on the Serial ATA interface and power connectors.

Table 5 Serial ATA connector pin definitions

Segment	Pin	Function	Definition
	S1	Ground	2nd mate
	S2	A+	Differential signal pair A from Phy
	S3	A-	
	S4	Ground	2nd mate
	S5	B-	Differential signal pair B from Phy
	S6	B+	
Signal	S7	Ground	2nd mate
Key and spacing separate signal and power segments			

Table 5 Serial ATA connector pin definitions

Segment	Pin	Function	Definition
Power	P1	V ₃₃	3.3V power
	P2	V ₃₃	3.3V power
	P3	V ₃₃	3.3V power, pre-charge, 2nd mate
	P4	Ground	1st mate
	P5	Ground	2nd mate
	P6	Ground	2nd mate
	P7	V ₅	5V power, pre-charge, 2nd mate
	P8	V ₅	5V power
	P9	V ₅	5V power
	P10	Ground	2nd mate
	P11	Ground or LED signal	If grounded, drive does not use deferred spin
	P12	Ground	1st mate.
	P13	V ₁₂	12V power, pre-charge, 2nd mate
	P14	V ₁₂	12V power
	P15	V ₁₂	12V power

Notes

- All pins are in a single row, with a 1.27 mm (0.050") pitch.
- The comments on the mating sequence apply to the case of backplane blindmate connector only. In this case, the mating sequences are:
 - the ground pins P4 and P12.
 - the pre-charge power pins and the other ground pins.
 - the signal pins and the rest of the power pins.
- There are three power pins for each voltage. One pin from each voltage is used for pre-charge when installed in a blind-mate backplane configuration.
 - All used voltage pins (V_x) must be terminated.

4.3 Supported ATA commands

The following table lists Serial ATA standard commands that the drive supports.

For a detailed description of the ATA commands, refer to the Serial ATA International Organization: Serial ATA Revision 3.0 (<http://www.sata-io.org>).

See "S.M.A.R.T. commands" on page 36 for details and subcommands used in the S.M.A.R.T. implementation.

Command name	Command code (in hex)
Check Power Mode	E5 _H
Device Configuration Freeze Lock	B1 _H / C1 _H
Device Configuration Identify	B1 _H / C2 _H
Device Configuration Restore	B1 _H / C0 _H
Device Configuration Set	B1 _H / C3 _H

Command name	Command code (in hex)
Device Reset	08 _H
Download Microcode	92 _H
Execute Device Diagnostics	90 _H
Flush Cache	E7 _H
Flush Cache Extended	EA _H
Format Track	50 _H
Identify Device	EC _H
Idle	E3 _H
Idle Immediate	E1 _H
Initialize Device Parameters	91 _H
Read Buffer	E4 _H
Read DMA	C8 _H
Read DMA Extended	25 _H
Read DMA Without Retries	C9 _H
Read Log Ext	2F _H
Read Multiple	C4 _H
Read Multiple Extended	29 _H
Read Native Max Address	F8 _H
Read Native Max Address Extended	27 _H
Read Sectors	20 _H
Read Sectors Extended	24 _H
Read Sectors Without Retries	21 _H
Read Verify Sectors	40 _H
Read Verify Sectors Extended	42 _H
Read Verify Sectors Without Retries	41 _H
Recalibrate	10 _H
Security Disable Password	F6 _H
Security Erase Prepare	F3 _H
Security Erase Unit	F4 _H
Security Freeze	F5 _H
Security Set Password	F1 _H
Security Unlock	F2 _H
Seek	70 _H
Set Features	EF _H

Command name	Command code (in hex)
Set Max Address Note: Individual Set Max Address commands are identified by the value placed in the Set Max Features register as defined to the right.	F9 _H Address: 00 _H Password: 01 _H Lock: 02 _H Unlock: 03 _H Freeze Lock: 04 _H
Set Max Address Extended	37 _H
Set Multiple Mode	C6 _H
Sleep	E6 _H
S.M.A.R.T. Disable Operations	B0 _H / D9 _H
S.M.A.R.T. Enable/Disable Autosave	B0 _H / D2 _H
S.M.A.R.T. Enable Operations	B0 _H / D8 _H
S.M.A.R.T. Execute Offline	B0 _H / D4 _H
S.M.A.R.T. Read Attribute Thresholds	B0 _H / D1 _H
S.M.A.R.T. Read Data	B0 _H / D0 _H
S.M.A.R.T. Read Log Sector	B0 _H / D5 _H
S.M.A.R.T. Return Status	B0 _H / DA _H
S.M.A.R.T. Save Attribute Values	B0 _H / D3 _H
S.M.A.R.T. Write Log Sector	B0 _H / D6 _H
Standby	E2 _H
Standby Immediate	E0 _H
Write Buffer	E8 _H
Write DMA	CA _H
Write DMA Extended	35 _H
Write DMA FUA Extended	3D _H
Write DMA Without Retries	CB _H
Write Log Extended	3F _H
Write Multiple	C5 _H
Write Multiple Extended	39 _H
Write Multiple FUA Extended	CE _H
Write Sectors	30 _H
Write Sectors Without Retries	31 _H
Write Sectors Extended	34 _H
Write Uncorrectable	45 _H

4.3.1 Identify Device command

The Identify Device command (command code EC_H) transfers information about the drive to the host following power up. The data is organized as a single 512-byte block of data, whose contents are shown in on page 28. All reserved bits or words should be set to zero. Parameters listed with an “x” are drive-specific or vary with the state of the drive.

The following commands contain drive-specific features that may not be included in the Serial ATA specification.

Word	Description	Value
0	Configuration information: <ul style="list-style-type: none"> • Bit 15: 0 = ATA; 1 = ATAPI • Bit 7: removable media • Bit 6: removable controller • Bit 0: reserved 	0C5A _H
1	Number of logical cylinders	16,383
2	ATA-reserved	0000 _H
3	Number of logical heads	16
4	Retired	0000 _H
5	Retired	0000 _H
6	Number of logical sectors per logical track: 63	003F _H
7–9	Retired	0000 _H
10–19	Serial number: (20 ASCII characters, 0000 _H = none)	ASCII
20	Retired	0000 _H
21	Retired	0400 _H
22	Obsolete	0000 _H
23–26	Firmware revision (8 ASCII character string, padded with blanks to end of string)	x.xx
27–46	Drive model number: (40 ASCII characters, padded with blanks to end of string)	
47	(Bits 7–0) Maximum sectors per interrupt on Read multiple and Write multiple (16)	8010 _H
48	Reserved	0000 _H
49	Standard Standby timer, IORDY supported and may be disabled	2F00 _H
50	ATA-reserved	0000 _H
51	PIO data-transfer cycle timing mode	0200 _H
52	Retired	0200 _H
53	Words 54–58, 64–70 and 88 are valid	0007 _H
54	Number of current logical cylinders	xxxx _H
55	Number of current logical heads	xxxx _H

Word	Description	Value
56	Number of current logical sectors per logical track	xxxx _H
57–58	Current capacity in sectors	xxxx _H
59	Number of sectors transferred during a Read Multiple or Write Multiple command	xxxx _H
60–61	Total number of user-addressable LBA sectors available (see Section 2.2 for related information) *Note: The maximum value allowed in this field is: 0FFFFFFF _H (268,435,455 sectors, 137GB). Drives with capacities over 137GB will have 0FFFFFFF _H in this field and the actual number of user-addressable LBAs specified in words 100-103. This is required for drives that support the 48-bit addressing feature.	0FFFFFFF _H *
62	Retired	0000 _H
63	Multiword DMA active and modes supported (see note following this table)	xx07 _H
64	Advanced PIO modes supported (modes 3 and 4 supported)	0003 _H
65	Minimum multiword DMA transfer cycle time per word (120 nsec)	0078 _H
66	Recommended multiword DMA transfer cycle time per word (120 nsec)	0078 _H
67	Minimum PIO cycle time without IORDY flow control (240 nsec)	00F0 _H
68	Minimum PIO cycle time with IORDY flow control (120 nsec)	0078 _H
69–74	ATA-reserved	0000 _H
75	Queue depth	001F _H
76	Serial ATA capabilities	xxxx _H
77	Reserved for future Serial ATA definition	xxxx _H
78	Serial ATA features supported	xxxx _H
79	Serial ATA features enabled	xxxx _H
80	Major version number	003E _H
81	Minor version number	0028 _H
82	Command sets supported	364B _H
83	Command sets supported	7C03 _H
84	Command sets support extension (see note following this table)	4003 _H See Word 108-111 note. (4003H = 0100000000000011 binary)
85	Command sets enabled	30xx _H
86	Command sets enabled	0001 _H

Word	Description	Value
87	Command sets enable extension	4000 _H
88	Ultra DMA support and current mode (see note following this table)	xx3F _H
89	Security erase time	0000 _H
90	Enhanced security erase time	0000 _H
92	Master password revision code	FFFE _H
93	Hardware reset value	xxxx _H
95–99	ATA-reserved	0000 _H
100–103	Total number of user-addressable LBA sectors available (see Section 2.2 for related information). These words are required for drives that support the 48-bit addressing feature. Maximum value: 0000FFFFFFFFFh.	ST500DM002 = 1,953,525,168 ST320DM000 = 1,465,149,168 ST250DM000 = 976,773,168
104–107	ATA-reserved	0000 _H
108–111	The mandatory value of the world wide name (WWN) for the drive. NOTE: This field is valid if word 84, bit 8 is set to 1 indicating 64-bit WWN support.	Each drive will have a unique value.
112–127	ATA-reserved	0000 _H
128	Security status	0001 _H
129–159	Seagate-reserved	xxxx _H
160–254	ATA-reserved	0000 _H
255	Integrity word	xxA5 _H

Note

Advanced Power Management (APM) and Automatic Acoustic Management (AAM) features are not supported.

Note

See the bit descriptions below for words 63, 84, and 88 of the Identify Drive data.

Description (if bit is set to 1)		
	Bit	Word 63
	0	Multiword DMA mode 0 is supported.
	1	Multiword DMA mode 1 is supported.
	2	Multiword DMA mode 2 is supported.
	8	Multiword DMA mode 0 is currently active.
	9	Multiword DMA mode 1 is currently active.
	10	Multiword DMA mode 2 is currently active.
	Bit	Word 84

	0	SMART error login is supported.
	1	SMART self-test is supported.
	2	Media serial number is supported.
	3	Media Card Pass Through Command feature set is supported.
	4	Streaming feature set is supported.
	5	GPL feature set is supported.
	6	WRITE DMA FUA EXT and WRITE MULTIPLE FUA EXT commands are supported.
	7	WRITE DMA QUEUED FUA EXT command is supported.
	8	64-bit World Wide Name is supported.
	9-10	Obsolete.
	11-12	Reserved for TLC.
	13	IDLE IMMEDIATE command with IUNLOAD feature is supported.
	14	Shall be set to 1.
	15	Shall be cleared to 0.
	Bit	Word 88
	0	Ultra DMA mode 0 is supported.
	1	Ultra DMA mode 1 is supported.
	2	Ultra DMA mode 2 is supported.
	3	Ultra DMA mode 3 is supported.
	4	Ultra DMA mode 4 is supported.
	5	Ultra DMA mode 5 is supported.
	6	Ultra DMA mode 6 is supported.
	8	Ultra DMA mode 0 is currently active.
	9	Ultra DMA mode 1 is currently active.
	10	Ultra DMA mode 2 is currently active.
	11	Ultra DMA mode 3 is currently active.
	12	Ultra DMA mode 4 is currently active.
	13	Ultra DMA mode 5 is currently active.
	14	Ultra DMA mode 6 is currently active.

4.3.2 Set Features command

This command controls the implementation of various features that the drive supports. When the drive receives this command, it sets BSY, checks the contents of the Features register, clears BSY and generates an interrupt. If the value in the register does not represent a feature that the drive supports, the command is aborted. Power-on default has the read look-ahead and write caching features enabled. The acceptable values for the Features register are defined as follows:

02 _H	Enable write cache (<i>default</i>).
03 _H	Set transfer mode (based on value in Sector Count register). Sector Count register values:
	00 _H Set PIO mode to default (PIO mode 2).
	01 _H Set PIO mode to default and disable IORDY (PIO mode 2).
	08 _H PIO mode 0
	09 _H PIO mode 1
	0A _H PIO mode 2
	0B _H PIO mode 3
	0C _H PIO mode 4 (<i>default</i>)
	20 _H Multiword DMA mode 0
	21 _H Multiword DMA mode 1
	22 _H Multiword DMA mode 2
	40 _H Ultra DMA mode 0
	41 _H Ultra DMA mode 1
	42 _H Ultra DMA mode 2
	43 _H Ultra DMA mode 3
	44 _H Ultra DMA mode 4
	45 _H Ultra DMA mode 5
	46 _H Ultra DMA mode 6
10 _H	Enable use of SATA features
55 _H	Disable read look-ahead (read cache) feature.
82 _H	Disable write cache
90 _H	Disable use of SATA features
AA _H	Enable read look-ahead (read cache) feature (<i>default</i>).
F1 _H	Report full capacity available

Note

At power-on, or after a hardware or software reset, the default values of the features are as indicated above.

4.3.3 S.M.A.R.T. commands

S.M.A.R.T. provides near-term failure prediction for disk drives. When S.M.A.R.T. is enabled, the drive monitors predetermined drive attributes that are susceptible to degradation over time. If self-monitoring determines that a failure is likely, S.M.A.R.T. makes a status report available to the host. Not all failures are predictable. S.M.A.R.T. predictability is limited to the attributes the drive can monitor. For more information on S.M.A.R.T. commands and implementation, see the *Draft ATA-5 Standard*.

SeaTools diagnostic software activates a built-in drive self-test (DST S.M.A.R.T. command for D4_H) that eliminates unnecessary drive returns. The diagnostic software ships with all new drives and is also available at:

<http://seatools.seagate.com>.

This drive is shipped with S.M.A.R.T. features disabled. You must have a recent BIOS or software package that supports S.M.A.R.T. to enable this feature. The table below shows the S.M.A.R.T. command codes that the drive uses.

Code in features register	S.M.A.R.T. command
D0 _H	S.M.A.R.T. Read Data
D2 _H	S.M.A.R.T. Enable/Disable Attribute Autosave
D3 _H	S.M.A.R.T. Save Attribute Values
D4 _H	S.M.A.R.T. Execute Off-line Immediate (runs DST)
D5 _H	S.M.A.R.T. Read Log Sector
D6 _H	S.M.A.R.T. Write Log Sector
D8 _H	S.M.A.R.T. Enable Operations
D9 _H	S.M.A.R.T. Disable Operations
DA _H	S.M.A.R.T. Return Status

Note	If an appropriate code is not written to the Features Register, the command is aborted and 0x04 (abort) is written to the Error register.
-------------	---

A

ACA 20
 acceleration 18
 acoustics 18
 Active 16
 Active mode 16
 Agency certification 20
 altitude 17
 Ambient temperature 17
 ambient temperature 14, 15
 Annualized Failure Rate 20
 areal density 14
 ATA commands 28
 Australia/New Zealand Standard AS/NZ CISPR22 20
 Australian Communication Authority (ACA) 20
 Australian C-Tick 20
 Average latency 14
 Average seek time 14

B

buffer 14

C

cables and connectors 23
 cache 14
 capacity 13
 case temperature 17
 CE mark 20
 certification 20
 Check Power Mode 28
 China RoHS directive 21
 compatibility 20
 Conducted noise 16
 Conducted RF immunity 19
 Configuring the drive 23
 connectors 23
 Corrosive environment 22
 CSA60950-1 20
 Cylinders 13

D

data-transfer rates 9
 DC power 15
 Default logical geometry 13
 density 14
 Device Configuration Freeze Lock 28
 Device Configuration Identify 28
 Device Configuration Restore 28
 Device Configuration Set 28
 Device Reset 29
 dimensions 25

dissipation 15
 Download Microcode 29

E

Electrical fast transient 19
 Electromagnetic compatibility 20
 Electromagnetic Compatibility (EMC) 20
 Electromagnetic Compatibility control Regulation 20
 Electromagnetic Compatibility Directive (2004/108/EC) 20
 Electromagnetic immunity 19
 Electrostatic discharge 19
 electrostatic discharge (ESD) 23
 EN 55022, Class B 20
 EN 55024 20
 EN60950 20
 enclosures 20
 Environmental specifications 17
 error-correction algorithms 9
 ESD 23
 EU 20
 EU RoHS directive 21
 European Union (EU) requirements 20
 Execute Device Diagnostics 29

F

FCC verification 20
 features 9
 Flush Cache 29
 Flush Cache Extended 29
 Format Track 29
 Formatted capacity 13

G

geometry 13
 Gs 18
 guaranteed sectors 13

H

Handling precautions 23
 heads 13
 height 14
 humidity 17

I

I/O data-transfer rate 14
 Identify Device 29
 Identify Device command 31
 Idle 16, 29
 Idle Immediate 29
 Idle mode 15, 16
 Information Technology Equipment (ITE) 20
 Initialize Device Parameters 29

Input noise ripple 16
input voltage 15
interface 14, 27
interference 20
internal data-transfer rate OD 14
is 14
ISO document 7779 18
ITE 20
K
KCC 20
Korean Communications Commission 20
Korean RRL 20
L
latency 14
LBA mode 13
length 14
logical geometry 13
M
master/slave 9
mounting 24
mounting screws 17
mounting the drive 23
N
noise 16
nominal power 14
Nonoperating shock 17
Nonoperating vibration 18
O
operating 15
Operating power 15
Operating shock 17
Operating vibration 18
P
Physical characteristics 14
point-to-point 9, 23
Power consumption 15
power dissipation 15
Power modes 16
Power specifications 15
Power-management modes 16
Power-on to Ready 15
precautions 23
printed circuit board 23
programmable power management 16
prominent discrete tone 18
Q
quick reference 11
R
Radiated RF immunity 19

radio and television interference 20
radio frequency (RF) 19
random seeks 15
Read Buffer 29
Read DMA 29
Read DMA Extended 29
Read DMA without Retries 29
Read Log Ext 29
Read Multiple 29
Read Multiple Extended 29
Read Native Max Address 29
Read Native Max Address Extended 29
Read Sectors 29
Read Sectors Extended 29
Read Sectors Without Retries 29
Read Verify Sectors 29
Read Verify Sectors Extended 29
Read Verify Sectors Without Retries 29
Read/write heads 13
Read/write power 15
Recalibrate 29
recording density 14
recording method 14
Recording technology 14
relative humidity 17
Reliability 20
RF 19
RMS read/write current 16
RoHS 21
RRL 20
S
S.M.A.R.T. Disable Operations 30
S.M.A.R.T. Enable Operations 30
S.M.A.R.T. Enable/Disable Autosave 30
S.M.A.R.T. Execute Offline 30
S.M.A.R.T. implementation 28
S.M.A.R.T. Read Attribute Thresholds 30
S.M.A.R.T. Read Data 30
S.M.A.R.T. Read Log Sector 30
S.M.A.R.T. Return Status 30
S.M.A.R.T. Save Attribute Values 30
S.M.A.R.T. Write Log sector 30
Safety certification 20
SATA 27
screws 17
sectors 13
Sectors per track 13
Security Disable Password 29
Security Erase Prepare 29

- Security Erase Unit 29
- Security Freeze 29
- Security Set Password 29
- Security Unlock 29
- See “S.M.A.R.T. commands” on page 34 28
- Seek 29
- Seek time 14
- Serial ATA (SATA) interface 27
- serial ATA ports 9
- servo electronics 15
- Set Features 29
- Set Max Address 30
- Set Max Address Extended 30
- Set Multiple Mode 30
- Shock 17
- single-track seeks 14
- Sleep 15, 16, 30
- Sleep mode 16
- sound 18
- Specification summary table 11
- spindle speed 14
- Spinup 15
- Spinup power 15
- Standby 15, 16, 30
- Standby Immediate 30
- Standby mode 15, 16
- standby timer 16
- Standby to Ready 15
- Start/stop times 15
- static-discharge 23
- subassembly 20
- support services 37
- Surge immunity 19

T

- technical support services 37
- temperature 14, 17
- temperature gradient 17
- timer 16
- timers 16
- track density 14
- Track-to-track 14
- Track-to-track seek time 14

U

- UL60950-1 20

V

- Vibration 18
- voltage 15
- Voltage dips, interrupts 19
- Voltage tolerance 16

W

- weight 14
- wet bulb temperature 17
- width 14
- Write Buffer 30
- Write DMA 30
- Write DMA Extended 30
- Write DMA FUA Extended 30
- Write DMA Without Retries 30
- Write Log Extended 30
- Write Multiple 30
- Write Multiple Extended 30
- Write Multiple FUA Extended 30
- Write Sectors 30
- Write Sectors Extended 30
- Write Sectors Without Retries 30



Seagate Technology LLC

AMERICAS Seagate Technology LLC 10200 South De Anza Boulevard, Cupertino, California 95014, United States, 408-658-1000

ASIA/PACIFIC Seagate Singapore International Headquarters Pte. Ltd. 7000 Ang Mo Kio Avenue 5, Singapore 569877, 65-6485-3888

EUROPE, MIDDLE EAST AND AFRICA Seagate Technology SAS 16-18 rue du Dôme, 92100 Boulogne-Billancourt, France, 33 1-4186 10 00

Publication Number: 100672652, Rev. B

August 2011