

**SUPER**  <sup>®</sup>

X8SAX

C7X58

**USER'S MANUAL**

Revision 1.3

---

---

The information in this User's Manual has been carefully reviewed and is believed to be accurate. The vendor assumes no responsibility for any inaccuracies that may be contained in this document, makes no commitment to update or to keep current the information in this manual, or to notify any person or organization of the updates. **Please Note: For the most up-to-date version of this manual, please see our web site at [www.supermicro.com](http://www.supermicro.com).**

Super Micro Computer, Inc. ("Supermicro") reserves the right to make changes to the product described in this manual at any time and without notice. This product, including software and documentation, is the property of Supermicro and/or its licensors, and is supplied only under a license. Any use or reproduction of this product is not allowed, except as expressly permitted by the terms of said license.

IN NO EVENT WILL SUPER MICRO COMPUTER, INC. BE LIABLE FOR DIRECT, INDIRECT, SPECIAL, INCIDENTAL, SPECULATIVE OR CONSEQUENTIAL DAMAGES ARISING FROM THE USE OR INABILITY TO USE THIS PRODUCT OR DOCUMENTATION, EVEN IF ADVISED OF THE POSSIBILITY OF SUCH DAMAGES. IN PARTICULAR, SUPER MICRO COMPUTER, INC. SHALL NOT HAVE LIABILITY FOR ANY HARDWARE, SOFTWARE, OR DATA STORED OR USED WITH THE PRODUCT, INCLUDING THE COSTS OF REPAIRING, REPLACING, INTEGRATING, INSTALLING OR RECOVERING SUCH HARDWARE, SOFTWARE, OR DATA.

Any disputes arising between manufacturer and customer shall be governed by the laws of Santa Clara County in the State of California, USA. The State of California, County of Santa Clara shall be the exclusive venue for the resolution of any such disputes. Supermicro's total liability for all claims will not exceed the price paid for the hardware product.

FCC Statement: This equipment has been tested and found to comply with the limits for a Class B digital device pursuant to Part 15 of the FCC Rules. These limits are designed to provide reasonable protection against harmful interference in a residential installation. This equipment generates, uses, and can radiate radio frequency energy and, if not installed and used in accordance with the manufacturer's instruction manual, may cause interference with radio communications. However, there is no guarantee that interference will not occur in a particular installation. If this equipment does cause harmful interference to radio or television reception, which can be determined by turning the equipment off and on, you are encouraged to try to correct the interference by one or more of the following measures:

- Reorient or relocate the receiving antenna.
- Increase the separation between the equipment and the receiver.
- Connect the equipment into an outlet on a circuit different from that to which the receiver is connected.
- Consult the dealer or an experienced radio/television technician for help.

California Best Management Practices Regulations for Perchlorate Materials: This Perchlorate warning applies only to products containing CR (Manganese Dioxide) Lithium coin cells. "Perchlorate Material-special handling may apply. See [www.dtsc.ca.gov/hazardouswaste/perchlorate](http://www.dtsc.ca.gov/hazardouswaste/perchlorate)".

**WARNING: Handling of lead solder materials used in this product may expose you to lead, a chemical known to the State of California to cause birth defects and other reproductive harm.**

---

Manual Revision 1.3

Release Date: February 22, 2012

Unless you request and receive written permission from Super Micro Computer, Inc., you may not copy any part of this document. Information in this document is subject to change without notice. Other products and companies referred to herein are trademarks or registered trademarks of their respective companies or mark holders.

Copyright © 2012 by Super Micro Computer, Inc. All rights reserved.

**Printed in the United States of America**

## Preface

This manual is written for system integrators, PC technicians and knowledgeable PC users. It provides information for the installation and use of the **SUPER**® X8SAX/C7X58 motherboard.

### About This Motherboard

The **SUPER**® X8SAX/C7X58 supports the Intel® Core™ i7 900 series / i7 Extreme Edition, and Intel® Xeon® 5500/3500 series processors. Xeon® 5600/3600 series processors are supported on PCB Rev. 2.0 with BIOS 2.0 and above. It is the first platform that supports the Intel QuickPath Interconnect technology, providing the next generation point-to-point system interface, replacing the current Front Side Bus. With the Intel X58 Express Chipset platform built-in, the X8SAX/C7X58 offers substantial enhancement in system performance with increased bandwidth and unprecedented scalability, optimized for intensive-applications and high-end workstations. Please refer to our web site (<http://www.supermicro.com/products/>) for updates on supported processors.

This product is intended to be installed and serviced by professional technicians.

### Manual Organization

**Chapter 1** describes the features, specifications and performance of the motherboard and provides detailed information about the chipset.

**Chapter 2** provides hardware installation instructions. Read this chapter when installing the processor, memory modules and other hardware components into the system. If you encounter any problems, see **Chapter 3**, which describes troubleshooting procedures for video, memory and system setup stored in the CMOS.

**Chapter 4** includes an introduction to the BIOS and provides detailed information on running the CMOS Setup utility.

**Appendix A** provides BIOS Error Beep Codes.

**Appendix B** lists Other Software Program Installation

**Appendix C** provides BIOS Recovery Instructions.

## Conventions Used in the Manual:

Special attention should be given to the following symbols for proper installation and to prevent damage done to the components or injury to yourself:



**Danger/Caution:** Instructions to be strictly followed to prevent catastrophic system failure or to avoid bodily injury



**Warning:** Important information given to ensure proper system installation or to prevent damage to the components



**Note:** Additional Information given to differentiate various models or provides information for correct system setup.

## Contacting Supermicro

### Headquarters

Address: Super Micro Computer, Inc.  
980 Rock Ave.  
San Jose, CA 95131 U.S.A.

Tel: +1 (408) 503-8000

Fax: +1 (408) 503-8008

Email: [marketing@supermicro.com](mailto:marketing@supermicro.com) (General Information)  
[support@supermicro.com](mailto:support@supermicro.com) (Technical Support)

Web Site: [www.supermicro.com](http://www.supermicro.com)

### Europe

Address: Super Micro Computer B.V.  
Het Sterrenbeeld 28, 5215 ML  
's-Hertogenbosch, The Netherlands

Tel: +31 (0) 73-6400390

Fax: +31 (0) 73-6416525

Email: [sales@supermicro.nl](mailto:sales@supermicro.nl) (General Information)  
[support@supermicro.nl](mailto:support@supermicro.nl) (Technical Support)  
[rma@supermicro.nl](mailto:rma@supermicro.nl) (Customer Support)

### Asia-Pacific

Address: Super Micro Computer, Inc.  
4F, No. 232-1, Liancheng Rd.  
Chung-Ho 235, Taipei County  
Taiwan, R.O.C.

Tel: +886-(2) 8226-3990

Fax: +886-(2) 8226-3991

Web Site: [www.supermicro.com.tw](http://www.supermicro.com.tw)

Technical Support:

Email: [support@supermicro.com.tw](mailto:support@supermicro.com.tw)

Tel: 886-2-8228-1366, ext.132 or 139

# Table of Contents

## **Preface**

About This Motherboard.....	3
Manual Organization .....	3
Conventions Used in the Manual:.....	4
Contacting Supermicro.....	5

## **Chapter 1 Introduction**

1-1 Overview .....	1-1
Checklist.....	1-1
Motherboard Features.....	1-6
1-2 Chipset Overview .....	1-11
Features of the LGA 1366 Processor and the X58 .....	1-11
1-3 PC Health Monitoring.....	1-12
Recovery from AC Power Loss.....	1-12
Onboard Voltage Monitoring .....	1-12
Fan Status Monitor with Software.....	1-12
CPU Overheat LED and Control .....	1-12
1-4 Power Configuration Settings.....	1-12
Slow Blinking LED for Suspend-State Indicator .....	1-13
BIOS Support for USB Keyboard.....	1-13
Main Switch Override Mechanism .....	1-13
1-5 Power Supply .....	1-13
1-6 Super I/O.....	1-14

## **Chapter 2 Installation**

2-1 Static-Sensitive Devices.....	2-1
Precautions .....	2-1
Unpacking .....	2-1
2-2 Processor and Heatsink Installation.....	2-2
Installing an Active Fan CPU Heatsink.....	2-4
Installing a Passive CPU Heatsink .....	2-6
2-3 Mounting the Motherboard into the Chassis.....	2-8
Tools Needed .....	2-8
2-4 Installing and Removing the Memory Modules.....	2-9
Installing & Removing DIMMs.....	2-9
2-5 Connectors/IO Ports.....	2-12
Back Panel Connectors and IO Ports.....	2-12
ATX PS/2 Keyboard and PS/2 Mouse Ports.....	2-13

---

---

	Universal Serial Bus (USB).....	2-14
	Ethernet Ports .....	2-15
	High Definition Audio (HDA).....	2-16
	CD-Input and FP Audio Headers .....	2-16
	Front Panel Audio Control.....	2-17
	S/PDIF_Out Connector .....	2-17
	Serial Ports.....	2-18
	Serial ATA Ports.....	2-18
	Front Control Panel.....	2-19
	Front Control Panel Pin Definitions.....	2-20
	NMI Button .....	2-20
	HDD LED.....	2-21
	NIC1/NIC2 LED Indicators .....	2-21
	Overheat (OH)/Fan Fail LED.....	2-22
	Power Fail LED .....	2-22
	Reset Button .....	2-23
	Power Button .....	2-23
2-6	Connecting Cables.....	2-24
	4-Pin Auxiliary Power Connector.....	2-24
	Fan Headers.....	2-25
	Internal Buzzer .....	2-26
	Speaker .....	2-26
	Overheat/Fan Fail LED (JOH1).....	2-27
	Chassis Intrusion .....	2-27
	Power Supply I <sup>2</sup> C Connector.....	2-28
	Onboard Power LED .....	2-28
	1394a_1/1394a_2 Connections.....	2-29
	T-SGPIO 0/1 Headers .....	2-29
	Wake-On-Ring.....	2-30
	Wake-On-LAN .....	2-30
2-7	Jumper Settings .....	2-31
	Explanation of Jumpers .....	2-31
	LAN Port Enable/Disable .....	2-31
	CMOS Clear.....	2-32
	Watch Dog Enable/Disable .....	2-32
	SMB to PCI-X/PCI-E Slots Speeds.....	2-33
	IEEE 1394a Enable .....	2-33
	Audio Enable .....	2-34

---

	USB Wake-Up .....	2-34
2-8	Onboard Indicators.....	2-35
	Onboard Power LED .....	2-35
2-9	Serial ATA and Floppy Drive Connections .....	2-36
	SATA Connectors .....	2-36
	Floppy Connector .....	2-37

**Chapter 3 Troubleshooting**

3-1	Troubleshooting Procedures .....	3-1
	Before Power On .....	3-1
	No Power .....	3-1
	No Video .....	3-1
	Memory Errors .....	3-2
	Losing the System's Setup Configuration .....	3-2
3-2	Technical Support Procedures .....	3-2
3-3	Frequently Asked Questions .....	3-3
3-4	Returning Merchandise for Service.....	3-5

**Chapter 4 BIOS**

4-1	Introduction.....	4-1
	Starting BIOS Setup Utility.....	4-1
	How To Change the Configuration Data .....	4-1
	Starting the Setup Utility .....	4-2
4-2	Main Setup.....	4-2
4-3	Advanced Setup Configurations.....	4-4
4-4	Security Settings .....	4-22
4-5	Boot Configuration .....	4-23
4-6	Exit Options.....	4-24

**Appendix A POST Error Beep Codes**

Recoverable POST Error Beep Codes .....	A-1
---	-----

**Appendix B Software Installation Instructions**

B-1	Installing Drivers.....	B-1
B-2	Configuring Supero Doctor III .....	B-2

**Appendix C - BIOS Recovery**

C-1	Recovery Process from a USB Device/Drive (Recommended Method).....	C-1
C-2	Recovery Process from an IDE/SATA ATAPI Disc Driv .....	C-2

# Chapter 1

## Introduction

### 1-1 Overview

#### Checklist

Thank you for purchasing your computer motherboard from an acknowledged leader in the industry. Supermicro boards are designed with the utmost attention to detail to provide you with the highest standards in quality and performance.

Please check that the following items have all been included with your motherboard. If anything listed here is damaged or missing, contact your retailer.

All the following items are included in the retail box only.

- One (1) Supermicro Mainboard
- Six (6) SATA cables (CBL-0044L)
- One (1) floppy drive ribbon cable (CBL-022L)
- One (1) 1394a connector, Internal header to external back panel cable (CBL-0173L)
- One (1) I/O shield (MCP-260-00030-0N)
- One (1) Supermicro CD containing drivers and utilities (CDR-X8-UP)
- One (1) SLI Bridge (AOC-SLIB) (C7X58 Only)
- One (1) User's/BIOS Manual (MNL-1063)

SUPER X8SAX Image

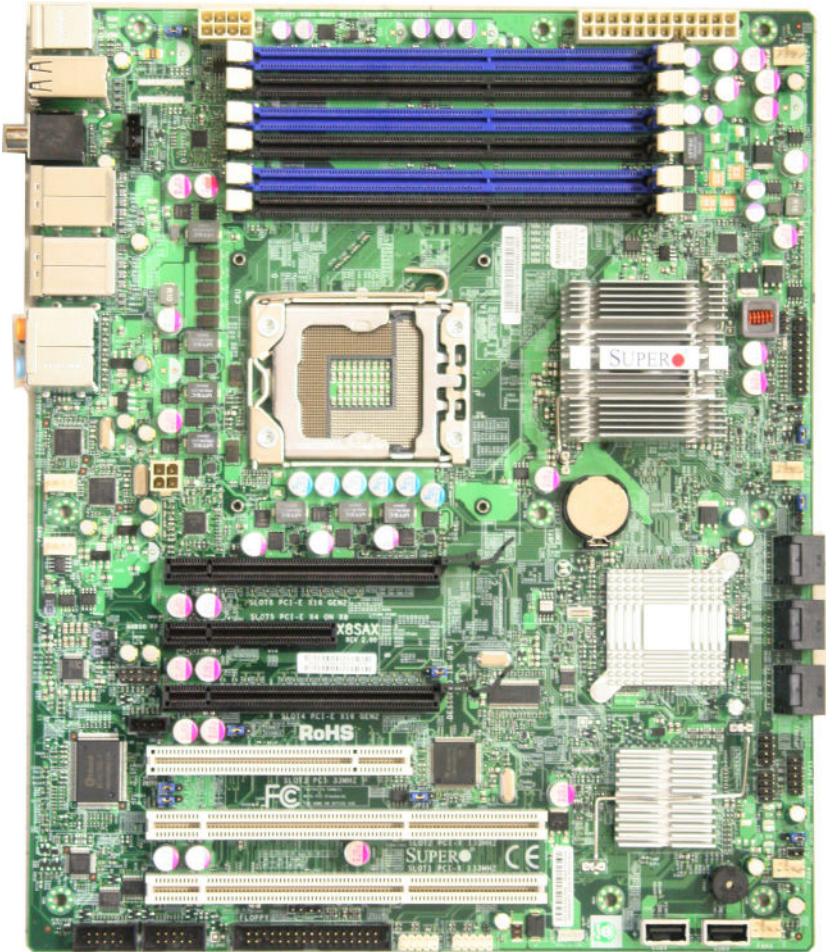

**Note:** All graphics shown in this manual were based upon the latest PCB Revision available at the time of publishing of the manual. The motherboard you've received may or may not look exactly the same as the graphics shown in this manual.





<b>Connector</b>	<b>Label</b>	<b>Description</b>
1394a_1/2	#25, 26	IEEE 1394a connection headers
Audio FP	#12	Front panel audio header
(HD) Audio	#6	(BP) High Definition Audio (7.1) header
Battery	#48	Onboard battery (B1)
CD-In	#15	Audio CD Input header
COM1/COM2	#22, 21	COM1/2 Serial connection headers
Fans 1~6	#8, 47, 36, 35, 54, 9	System/CPU fan headers (Fan 1: CPU fan)
Floppy	#24	Floppy Disk Drive connector
JD1	#46	Speaker header (Pins 3/4: Internal,3~4:Ext.)
JF1	#51	Front Panel Control header
JL1	#37	Chassis Intrusion header
JLED	#53	Power LED Indicator header
JOH1	#50	Overheat LED header
JPW1	#55	24-pin ATX main power connector
JPW2	#56	+12V 8-pin CPU power connector
JPW3	#7	+12V 4-pin Secondary power connector (this is recommended, but not required for normal operation)
JWOL	#29	Wake-On-LAN header
JWOR	#23	Wake-On-Ring header
KB/Mouse	#1	Keyboard/mouse connectors
LAN1/LAN2	#4, 5	Gigabit Ethernet (RJ45) ports
I-SATA 0~5	#44, 43, 42	(Intel South Bridge) SATA ports 0/1, 2/3, 4/5
Slot 1/Slot 2	#20, 19	PCI-X 133/100 MHz slots (X8SAX only)
Slot 3	#16	PCI 33 MHz slot
Slot 4/ Slot 6	#13, 10	PCI-Express x16 Generation 2 slots
Slot 5	#11	PCI-E x4 x8 slot
SMB_PS	#58	PWR supply (I <sup>2</sup> C) System Management Bus
S/PDIF	#3	Digital audio/video interface connector
SPKR1	#33	Internal speaker/buzzer
T-SGPIO-0/1	#41, 39	Serial General Purpose Input/Output headers
USB0~3, USB4/5, 6/7	#2, 4, 5	(Backpanel) Universal Serial Bus (USB) ports
USB8, USB9, USB10/11	#32, 34, 40	Front panel accessible USB headers
<b>LED</b>	<b>Label</b>	<b>Description</b>
LE1	#52	Onboard Standby PWR warning LED Indicator

## Motherboard Features

### CPU

- Single Intel® Core™ i7 900 series, i7 Extreme Edition, and Intel® Xeon® 5500/3500 series processors in an LGA1366 socket. Xeon® 5600/3600 series processors are supported on PCB Rev. 2.0 with BIOS 2.0 and above.

### Memory

- Six 240-pin, DDR3 SDRAM DIMM sockets with support for unbuffered ECC (if supported by CPU) or non ECC 1333/1066/800 MHz memory.
- Supports non ECC 1600 MHz XMP memory when an Extreme Edition CPU is installed (This feature is supported on the C7X58 motherboard only, see pages 2-10, 3-3, 3-4 and 4-11 for more information.)
- Supports 3-channel memory bus
- DIMM sizes of 256 MB, 512 MB, 1 GB, 2 GB, and 4 GB are supported

### Chipset

- Intel® X58 Express Chipset (IOH)
- Intel ICH10R (South Bridge)
- Intel PXH/V (I/O Bridge) for PCI-X slots (X8SAX only)

### Expansion Slots

- Two (2) PCI-Express x16 Gen2 slots (Slot 6/Slot 4)
- One PCI-Express x4 in x8 slot (Slot 5)
- Two (2) PCI-X 133/100 MHz slots (Slot 1/Slot 2) (X8SAX only)
- One (1) 32-bit PCI 33MHz slot (Slot 3)

### Audio

- The HD ALC883 Audio Controller supports 7.1 channel High Definition audio interface
- One HD Audio connector on the IO backplane supports 8-channel (7.1) audio with Line-in/Line-out/Microphone built-in
- One S/PDIF connector on the IO backplane supports Digital Audio/Video Interface
- One additional onboard audio header (Audio FP) and a CD input header (CD-In) for front access

### Graphics

- Support for multiple PCI-Express Graphics cards (Gen 2 or Gen 1)
- Supports ATI® CrossFireX™ Technology
- Supports nVidia® SLi™ Technology (C7X58 only)

## **Network Connections**

- Two Intel 82574L Gigabit (10/100/1000 Mb/s) Ethernet Controllers with two Gigabit LAN ports
- Two (2) RJ-45 backplane connectors with Link and Activity LEDs built-in

## **I/O Devices**

### **SATA Connections**

- Six (6) SATA ports supported by the Intel ICH10R SATA Controller
- Supports RAID 0, 1, 5, 10 under the Windows OS environment

### **Floppy Drive**

- One (1) floppy port interface (up to 1.44 MB)

### **USB Devices**

- Eight (8) USB ports (USB 0~3, USB 4/5, USB 6/7) on the IO backplane for rear access
- Four (4) USB connections for front access (Two Type A connectors and one header)

### **Keyboard/Mouse**

- PS/2 Keyboard/Mouse ports on the I/O backplane

### **Serial (COM) Ports**

- Two (2) Fast UART 16550 headers

### **Super I/O**

- Winbond Super I/O 83627DHG

## **BIOS**

- 32Mb SPI AMI BIOS® SM Flash BIOS
- DMI 2.3, PCI 2.3, ACPI 1.0/2.0/3.0, and SMBIOS 2.5

## **Power Configuration**

- ACPI/ACPM Power Management
- Main switch override mechanism
- Keyboard Wake-up from Soft-Off
- Power-on mode for AC power recovery
- External modem ring-on
- Suspend to RAM (STR)

## PC Health Monitoring

### CPU Monitoring

- Onboard voltage monitors for CPU core, Memory Voltage, Chipset Voltage, +1.8V, +3.3V, +3.3V standby, +5V, +5V, Standby, VBat and  $\pm 12V$
- CPU 6-Phase-switching voltage regulator
- CPU/System overheat LED and control
- CPU Thermal Trip support
- Thermal Monitor 2 (TM2) support

### Fan Control

- Fan status monitoring with firmware 4-pin PWM (Pulse Width Modulation) fan speed control
- Low noise fan speed control

## System Management

- PECI (Platform Environment Configuration Interface) support
- System resource alert via SUPER<sup>®</sup> Doctor III
- SUPER<sup>®</sup> Doctor III, Watch Dog, NMI
- I<sup>2</sup>C temperature sensing logic
- Chassis Intrusion Header and Detection
- Pb Free

## CD Utilities

- BIOS flash upgrade utility
- Drivers and software for Intel<sup>®</sup> X58 Express chipset utilities

## Dimensions

- ATX form factor, 12" x 10" (304.8 x 254.0 mm)

## Notes

X8SAX / C7X58 Block Diagram

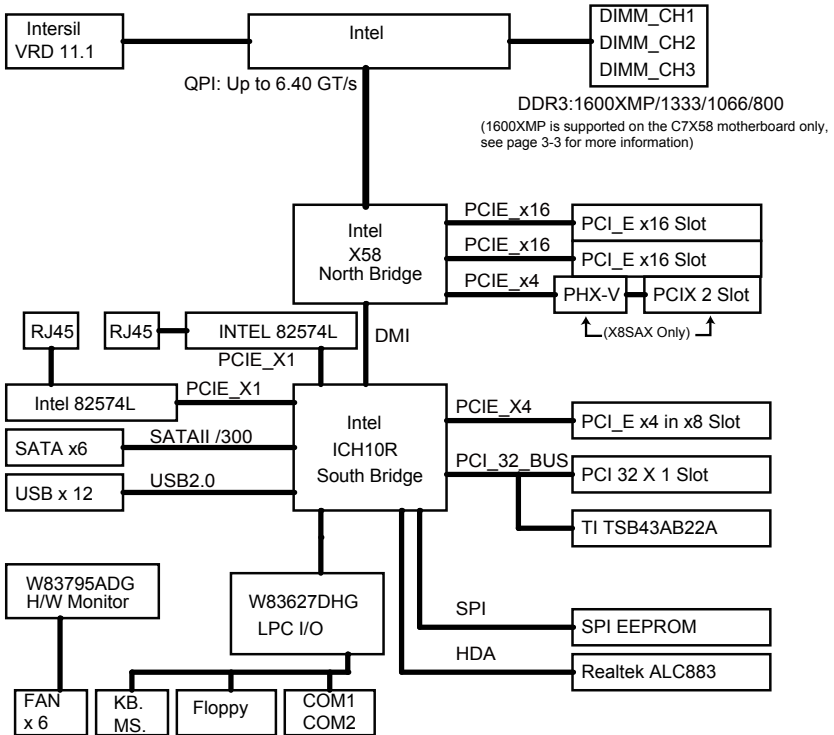

X8SAX/C7X58 System Block Diagram

**Note:** This is a general block diagram and may not exactly represent the features on your motherboard. See the following pages for the actual specifications of each motherboard.

## 1-2 Chipset Overview

Built upon the functionality and the capability of the Intel X58 Express chipset, the X8SAX/C7X58 motherboard provides the performance and feature set required for dual-processor systems with configuration options optimized for intensive application and high-end workstation platforms.

The main architecture of the X8SAX/C7X58 consists of an LGA 1366 processor socket, the Intel X58 Express North Bridge chipset, the ICH10R South Bridge, and the PXH/V IO Bridge. With Intel QuickPath Interconnect technology built in, the X8SAX/C7X58 is one of the first motherboards on the market that offer the next generation point-to-point system interconnect interface, replacing the current Front Side Bus Technology, providing substantial system performance enhancement by utilizing serial link interconnections to increase bandwidth and scalability.

### **Features of the LGA 1366 Processor and the X58**

- Intel QuickPath Interconnect link, up to 6.4 GT/s of data transfer rate in each direction
- Virtualization Technology, Integrated Management Engine supported
- Point-to-point cache coherent interconnect, Fast/narrow unidirectional links, and Concurrent bi-directional traffic
- Error detection via CRC and Error correction via Link level retry

## 1-3 PC Health Monitoring

This section describes the PC health monitoring features of the X8SAX/C7X58. The motherboard has an onboard System Hardware Monitor chip that supports PC health monitoring.

### Recovery from AC Power Loss

BIOS provides a setting for you to determine how the system will respond when AC power is lost and then restored to the system. You can choose for the system to remain powered off (in which case you must hit the power switch to turn it back on) or for it to automatically return to a power on state. See the Power Lost Control setting in the BIOS chapter of this manual to change this setting. The default setting is **Last State**.

### Onboard Voltage Monitoring

The onboard voltage monitor will scan the following voltages continuously: CPU Core, Chipset Voltage, Memory Voltage, +1.8V, +3.3V, +3.3V standby, +5V, +5V Standby, Vbat and  $\pm 12V$ . Once a voltage becomes unstable, it will give a warning or send an error message to the screen. Users can adjust the voltage thresholds to define the sensitivity of the voltage monitor by using SD III.

### Fan Status Monitor with Software

PC health monitoring can check the RPM status of the cooling fans via Supero Doctor III.

### CPU Overheat LED and Control

This feature is available when the user enables the CPU overheat warning feature in the BIOS. This allows the user to define an overheat temperature. When this temperature reaches this pre-defined overheat threshold, the CPU thermal trip feature will be activated and it will send a signal to the buzzer and, at the same time, the CPU speed will be decreased.

## 1-4 Power Configuration Settings

This section describes the features of your motherboard that deal with power and power settings.

## Slow Blinking LED for Suspend-State Indicator

When the CPU goes into a suspend state, the chassis power LED will start blinking to indicate that the CPU is in the suspend mode. When the user presses any key, the CPU will wake-up and the LED indicator will automatically stop blinking and remain on.

## BIOS Support for USB Keyboard

If the USB keyboard is the only keyboard in the system, it will function like a normal keyboard during system boot-up.

## Main Switch Override Mechanism

When an ATX power supply is used, the power button can function as a system suspend button. When the user presses the power button, the system will enter a SoftOff state. The monitor will be suspended and the hard drive will spin down. Pressing the power button again to wake-up the whole system. During the SoftOff state, the ATX power supply provides power the system to keep the required circuitry "alive". In case the system malfunctions and you want to turn off the power, just press and hold the power button for 4 seconds. The power will turn off and no power will be provided to the motherboard.

## 1-5 Power Supply

As with all computer products, a stable power source is necessary for proper and reliable operation. It is even more important for processors that have high CPU clock rates of 1 GHz and faster.

The **SUPER**® X8SAX/C7X58 accommodates ATX12V standard power supplies. Although most power supplies generally meet the specifications required by the CPU, some are inadequate. A 2-Amp of current supply on a 5V Standby rail is strongly recommended.

It is strongly recommended that you use a high quality power supply that meets ATX12V standard power supply Specification 1.1 or above. It is also required that the 12V 8-pin power connection (JPW2) and the 12V 4-pin power connection (JPW3) be used for adequate power supply. In areas where noisy power transmission is present, you may choose to install a line filter to shield the computer from noise. It is recommended that you also install a power surge protector to help avoid problems caused by power surges.

## 1-6 Super I/O

The disk drive adapter functions of the Super I/O chip include a floppy disk drive controller that is compatible with industry standard 82077/765, a data separator, write pre-compensation circuitry, decode logic, data rate selection, a clock generator, drive interface control logic and interrupt and DMA logic. The wide range of functions integrated onto the Super I/O greatly reduces the number of components required for interfacing with floppy disk drives. The Super I/O supports two 360 K, 720 K, 1.2 M, 1.44 M or 2.88 M disk drives and data transfer rates of 250 Kb/s, 500 Kb/s or 1 Mb/s.

It also provides two high-speed, 16550 compatible serial communication ports (UARTs). Each UART includes a 16-byte send/receive FIFO, a programmable baud rate generator, complete modem control capability and a processor interrupt system. Both UARTs provide legacy speed with baud rate of up to 115.2 Kbps as well as an advanced speed with baud rates of 250 K, 500 K, or 1 Mb/s, which support higher speed modems.

The Super I/O provides functions that comply with ACPI (Advanced Configuration and Power Interface), which includes support of legacy and ACPI power management through a SMI or SCI function pin. It also features auto power management to reduce power consumption.

## Chapter 2

### Installation

#### 2-1 Static-Sensitive Devices

Electrostatic-Discharge (ESD) can damage electronic components. To prevent damage to your system board, it is important to handle it very carefully. The following measures are generally sufficient to protect your equipment from ESD.

##### **Precautions**

- Use a grounded wrist strap designed to prevent static discharge.
- Touch a grounded metal object before removing the board from the antistatic bag.
- Handle the board by its edges only; do not touch its components, peripheral chips, memory modules or gold contacts.
- When handling chips or modules, avoid touching their pins.
- Put the motherboard and peripherals back into their antistatic bags when not in use.
- For grounding purposes, make sure your computer chassis provides excellent conductivity between the power supply, the case, the mounting fasteners and the motherboard.
- Use only the correct type of onboard CMOS battery. Do not install the onboard upside down battery to avoid possible explosion.

##### **Unpacking**

The motherboard is shipped in antistatic packaging to avoid static damage. When unpacking the board, make sure the person handling it is static protected.

## 2-2 Processor and Heatsink Installation



When handling the processor package, avoid placing direct pressure on the label area of the fan.

### Notes:

1. Always connect the power cord last and always remove it before adding, removing or changing any hardware components. Make sure that you install the processor into the CPU socket before you install the CPU heatsink.
2. Intel's boxed processor package contains the CPU fan and heatsink assembly. If you buy a CPU separately, make sure that you use only Intel-certified multi-directional heatsink and fan.
3. Make sure to install the motherboard into the chassis before you install the CPU heatsink and heatsink fans.
4. When purchasing an LGA 1366 processor or when receiving a motherboard with an LGA 1366 processor pre-installed, make sure that the CPU plastic cap is in place, and none of the CPU pins are bent; otherwise, contact the retailer immediately.
5. Refer to the MB Features Section for more details on CPU support.

### Installing an LGA 1366 Processor

1. Press the socket clip to release the load plate, which covers the CPU socket, from its locking position.
2. Gently lift the socket clip to open the load plate.
3. Hold the plastic cap at its north and south center edges to remove it from the CPU socket.



**Socket Clip**

**Load Plate**

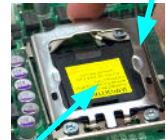

**Plastic Cap**

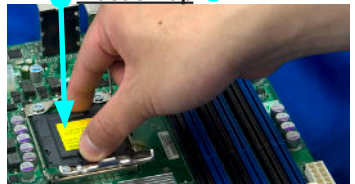

**Hold the north & south edges of the plastic cap to remove it**



Note: The photos on this page and succeeding pages 2-3 through 2-9 are for illustration purposes only. They do not necessarily reflect the exact product(s) described in this manual.

4. After removing the plastic cap, using your thumb and the index finger, hold the CPU at the north and south center edges.
5. Align the CPU key, the semi-circle cutout, against the socket key, the notch below the gold color dot on the side of the socket.
6. Once both the CPU and the socket are aligned, carefully lower the CPU straight down into the socket. (Do not rub the CPU against the surface of the socket or its pins to avoid damaging the CPU or the socket.)
7. With the CPU inside the socket, inspect the four corners of the CPU to make sure that the CPU is properly installed.
8. Once the CPU is securely seated on the socket, lower the CPU load plate to the socket.
9. Use your thumb to gently push the socket clip down to the clip lock.



**Warning:** Please save the plastic cap. The motherboard must be shipped with the plastic cap properly installed to protect the CPU socket pins. Shipment without the plastic cap properly installed will cause damage to the socket pins.

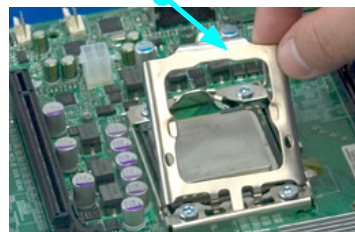
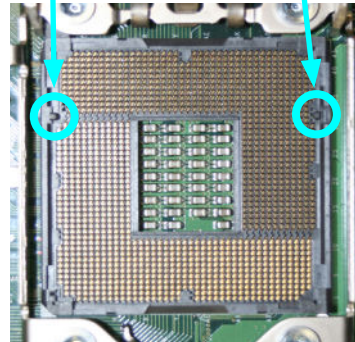
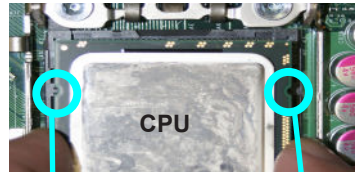
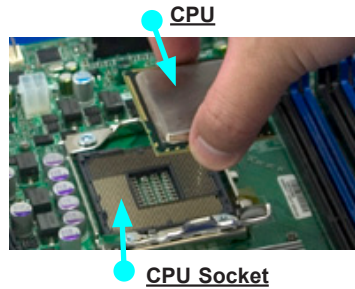

## Installing an Active Fan CPU Heatsink

1. Locate the CPU Fan power connector on the motherboard. (Refer to the layout on the right for the CPU Fan location.)
2. Position the heatsink so that the heatsink fan wires are closest to the CPU fan power connector and are not interfered with other components.
3. Inspect the CPU Fan wires to make sure that the wires are routed through the bottom of the heatsink.
4. Remove the thin layer of the protective film from the copper core of the heatsink.

(Warning: CPU may overheat if the protective film is not removed from the heatsink.)

5. Apply the proper amount of thermal grease on the CPU. (Note: if your heatsink came with a thermal pad, please ignore this step.)
6. If necessary, rearrange the wires to make sure that the wires are not pinched between the heatsink and the CPU. Also make sure to keep clearance between the fan wires and the fins of the heatsink.

Thermal Grease

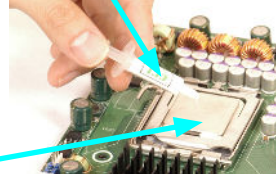

CPU

Fan Wires

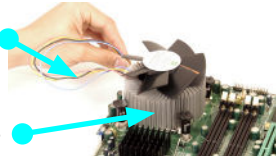

Heatsink Fins

Heatsink  
Fastener



7. Align the four heatsink fasteners with the mounting holes on the motherboard. Gently push the pairs of diagonal fasteners (#1 & #2, and #3 & #4) into the mounting holes until you hear a click. (Note: Make sure to orient each fastener so that the narrow end of the groove is pointing outward.)



Narrow end of the groove should point outward

8. Repeat Step 7 to insert all four heatsink fasteners into the mounting holes.

9. Once all four fasteners are securely inserted into the mounting holes and the heatsink is properly installed on the motherboard, connect the heatsink fan wires to the CPU Fan connector.

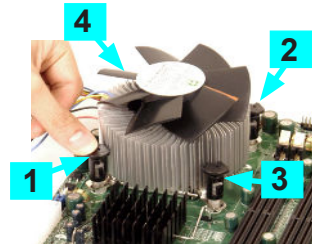

### Removing the Heatsink



**Warning:** We do not recommend that the CPU or the heatsink be removed. However, if you do need to remove the heatsink, please follow the instructions below to uninstall the heatsink and prevent damage to the CPU or other components.

#### Active Heatsink Removal

1. Unplug the power cord from the power supply.
2. Disconnect the heatsink fan wires from the CPU fan header.
3. Use your finger tips to gently press on the fastener cap and turn it counterclockwise to make a 1/4 (90°) turn, and then pull the fastener upward to loosen it.
4. Repeat Step 3 to loosen all fasteners from the mounting holes.
5. With all fasteners loosened, remove the heatsink from the CPU.



## Installing a Passive CPU Heatsink



Note: Passive CPU Heatsinks that have been purchased from Supermicro will include the optional heatsink bracket. Heatsinks purchased elsewhere may not include this bracket, but is available separately from Supermicro.

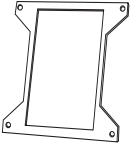

Optional Heatsink Bracket  
Part# BKT-0023L



**WARNING:** Before proceeding through this section, please make sure the optional bracket for the heatsink is attached underneath the motherboard.

1. Locate the four heatsink mounting holes on the reverse side of the motherboard and four heatsink lock alignments on the heatsink bracket.
2. Align the four bracket lock alignments on the heatsink bracket against the four mounting holes on the back of the motherboard. Place the heatsink bracket on the motherboard.
3. Do not apply any thermal grease to the heatsink or the CPU because the required amount has already been applied.
4. Place the heatsink on top of the CPU so that the four mounting holes are aligned with those on the bracket now located underneath.

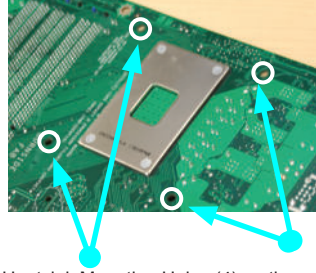

Heatsink Mounting Holes (4) on the motherboard. Mount the optional heatsink bracket here

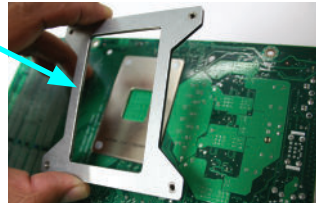

Align the Heatsink Mounting Holes (4) on the motherboard with the screw holes of the heatsink bracket



Optional heatsink bracket mounted

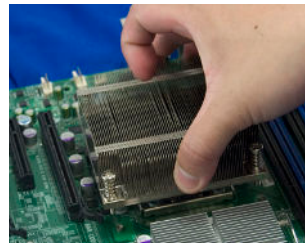

5. Screw in two diagonal screws (i.e., the #1 and the #2 screws) until secure. However, leave each loosely tightened until all four screws are in place.
6. Finish the installation by fully tightening all four screws. Do not over-tighten to avoid possible damage to the CPU.

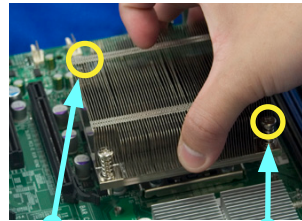

Screw#1

Screw#2

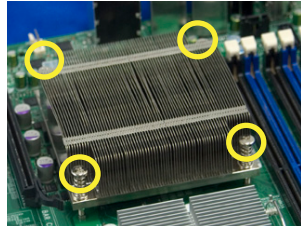

### Passive Heatsink Removal

1. Unplug the power cord from the power supply.
2. Using a screwdriver, loosen and remove the heatsink screws from the motherboard in the sequence as shown in the picture on the right.
3. Hold the heatsink as shown and gently loosen it from the CPU by moving it from side to side. (Do not use excessive force)
4. Once it is loosened, remove the heatsink from the CPU socket.
5. To reinstall the CPU and the heatsink, clean the surface of the CPU and the heatsink to remove the old thermal grease. Reapply the proper amount of thermal grease on the surface before reinstalling them on the motherboard.

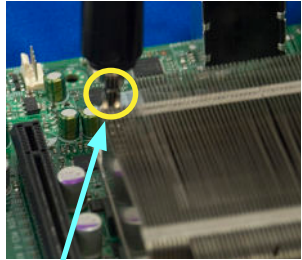

Using a screwdriver to  
remove Screw#1

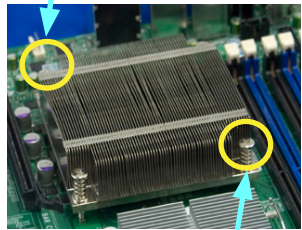

Remove Screw#2

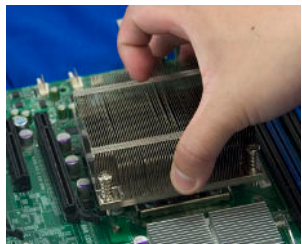

## 2-3 Mounting the Motherboard into the Chassis

All motherboards have standard mounting holes to fit different types of chassis. Make sure that the locations of all mounting holes for the motherboard and the chassis match. Although a chassis may have both plastic and metal mounting fasteners, metal ones are highly recommended because they ground the motherboard to the chassis. Make sure that the metal standoffs click in or are screwed in tightly. Then use a screwdriver to secure the motherboard onto the motherboard tray. (See the layout on the right for mounting hole locations.)



**Note:** Some components are very close to the mounting holes. Please take all necessary precautionary measures to avoid damaging these components when installing the motherboard into the chassis.

### Tools Needed

1. Philips Screwdriver
2. (9) Pan head #6 screws

### Installation Instructions

1. Install the I/O shield in your chassis. This is provided with your motherboard.
2. Locate the mounting holes on the motherboard. Refer to the layout on the right for mounting hole locations.
3. Place Standoffs on the chassis as needed.
4. Place the motherboard inside the chassis.
5. Locate the matching mounting holes on the chassis. Align the mounting holes on the motherboard against the mounting holes on the chassis.
6. Insert a Pan head #6 screw into a mounting hole on the motherboard and its matching mounting hole on the chassis, using a Philips screwdriver.
7. Repeat Step 6 until all mounting holes are secured.

Location of Mounting Holes

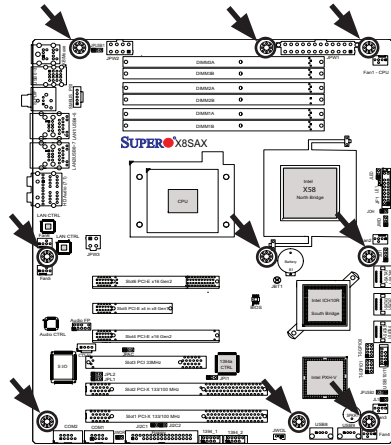

**Caution:** To avoid damaging the motherboard and its components, please do not use a force greater than 8 lb/inch on each mounting screw during motherboard installation.

## 2-4 Installing and Removing the Memory Modules

**Note:** Check the Supermicro web site for recommended memory modules.



### CAUTION

Exercise extreme care when installing or removing DIMM modules to prevent any possible damage.

### Installing & Removing DIMMs

1. Insert the desired number of DIMMs into the memory slots, starting with DIMM1A. When populating multiple DIMM modules within a channel, always start with Bank1 first. (For best performance, please use the memory modules of the same type and same speed in the same motherboard.)
2. Press down the release tabs on the ends of a memory slot. Insert each DIMM module vertically into its slot. Pay attention to the notch along the bottom of the module to prevent inserting the DIMM module incorrectly.
3. Gently press down on the DIMM module until it snaps into place in the slot. Repeat for all modules.
4. Reverse the steps above to remove the DIMM modules from the motherboard.

Press down the release tabs

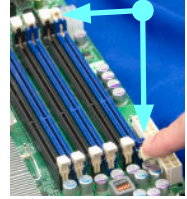

Insert & press down a DIMM module into the slot

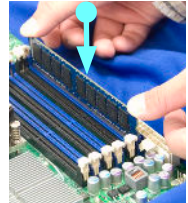

### Installing and Removing DDR3 Memory

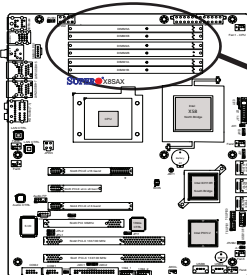

#### To Remove:

Use your thumbs to gently push the release tabs near both ends of the module. This should release it from the slot.

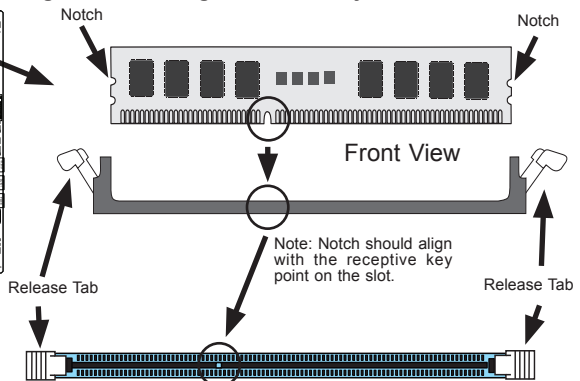

#### Top View of DDR3 Slot

**To Install:** Insert module vertically and press down until it snaps into place. Pay attention to the alignment notch at the bottom.

## Memory Support

### DIMM Module Population Configuration

#### Maximum Memory Possible

Single Rank UDIMMs - 12GB (6x 2GB DIMMs), Dual Rank UDIMMs - 24GB (6x 4GB DIMMs). See **Note 5** on the next page for XMP memory support (C7X58 only).

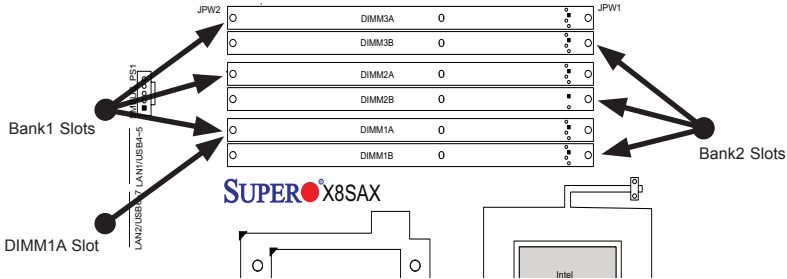

#### Population Recommendation

**Optimal Performance:** Populate ALL DIMM slots (Bank1 + Bank2).

**High Performance:** Populate DIMM1A ~ DIMM3A slots (Bank1).

**Performance:** Install one DIMM in slot DIMM1A (the first slot in Bank1), OR one DIMM each in slot DIMM1A and DIMM2A (the first two slots of Bank1).

**Populating DIMM modules with pairs of memory modules of the same size and same type will activate Memory Interleaving which will result in increased memory performance.**



**Note 1 :** The motherboard will NOT boot if DIMM module(s) are installed in any of the Bank2 slots but none in the Bank1 slots. The first DIMM module must be installed in DIMM1A, and all Bank1 slots must be filled before populating any Bank2 slot(s).

**Note 2:** Due to OS limitations, some operating systems may not show more than 4 GB of memory.

**Note 3:** Due to memory allocation to system devices, the memory available for operational use will be reduced when 4 GB of RAM is used. The reduction in memory availability is disproportional. Refer to the table on the following page.



**Note 4:** For Microsoft Windows users: Microsoft implemented a design change in Windows XP with Service Pack 2 (SP2) and Windows Vista. This change is specific to the Physical Address Extension (PAE) mode behavior which improves driver compatibility. For more information, please read the following article at Microsoft's Knowledge Base website at: <http://support.microsoft.com/kb/888137>.

**Note 5:** Up to three Core i7 1600 XMP DDR3 DIMM Modules are supported on the C7X58 motherboard (one DIMM per channel). However, XMP mode will only work if a Core i7 Extreme Edition CPU and Core i7 XMP memory are both installed. See Page 4-11 to activate XMP mode in the BIOS.

Possible System Memory Allocation & Availability		
System Device	Size	Physical Memory Remaining (-Available) (4 GB Total System Memory)
Firmware Hub flash memory (System BIOS)	1 MB	3.99 GB
Local APIC	4 KB	3.99 GB
Area Reserved for the chipset	2 MB	3.99 GB
I/O APIC (4 Kbytes)	4 KB	3.99 GB
PCI Enumeration Area 1	256 MB	3.76 GB
PCI Express (256 MB)	256 MB	3.51 GB
PCI Enumeration Area 2 (if needed) -Aligned on 256-MB boundary-	512 MB	3.01 GB
VGA Memory	16 MB	2.85 GB
TSEG	1 MB	2.84 GB
Memory available for the OS & other applications		2.84 GB

## 2-5 Connectors/IO Ports

The I/O ports are color coded in conformance with the PC 99 specification. See the figure below for the colors and locations of the various I/O ports.

### Back Panel Connectors and IO Ports

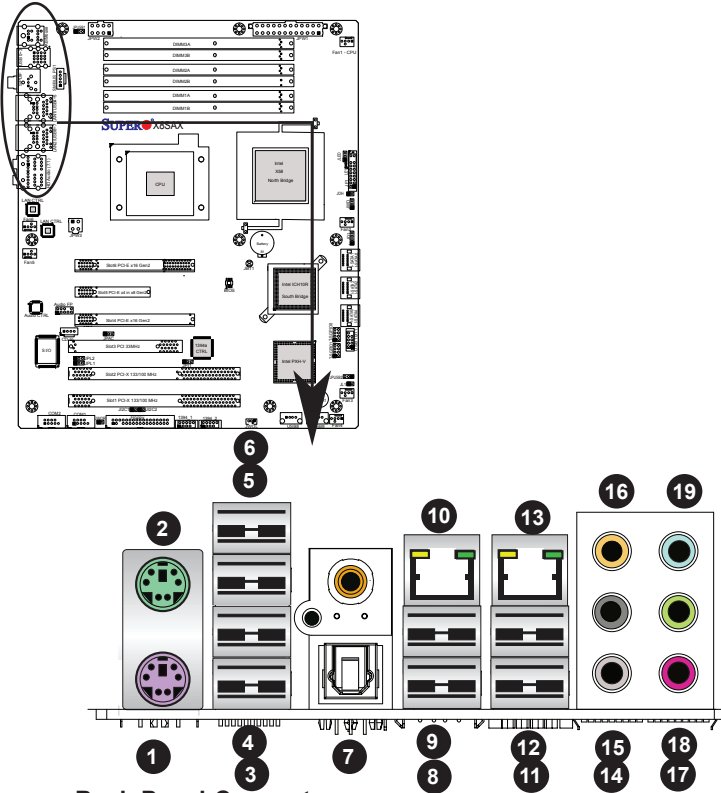

**Back Panel Connectors**

1. Keyboard (Purple)	11. USB Port 6
2. PS/2 Mouse (Green)	12. USB Port 7
3. USB Port 0	13. LAN2
4. USB Port 1	14. Side_Surround (Grey)
5. USB Port 2	15. Back_Surround (Black)
6. USB Port 3	16. CEN/LFE (Orange)
7. S/PDIF	17. Microphone-In (Pink)
8. USB Port 4	18. Front (Green)
9. USB Port 5	19. Line-In (Blue)
10. LAN 1	

## ATX PS/2 Keyboard and PS/2 Mouse Ports

The ATX PS/2 keyboard and PS/2 mouse are located next to the Back Panel USB Ports 1~2 on the motherboard. See the table at right for pin definitions.

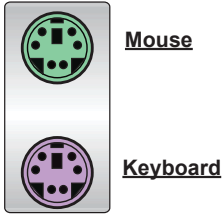

PS/2 Keyboard/Mouse Pin Definitions			
PS2 Keyboard		PS2 Mouse	
Pin#	Definition	Pin#	Definition
1	KB Data	1	Mouse Data
2	No Connection	2	No Connection
3	Ground	3	Ground
4	Mouse/KB VCC (+5V)	4	Mouse/KB VCC (+5V)
5	KB Clock	5	Mouse Clock
6	No Connection	6	No Connection

VCC: with 1.5A PTC (current limit)

1. Keyboard (Purple)

2. Mouse (Green)

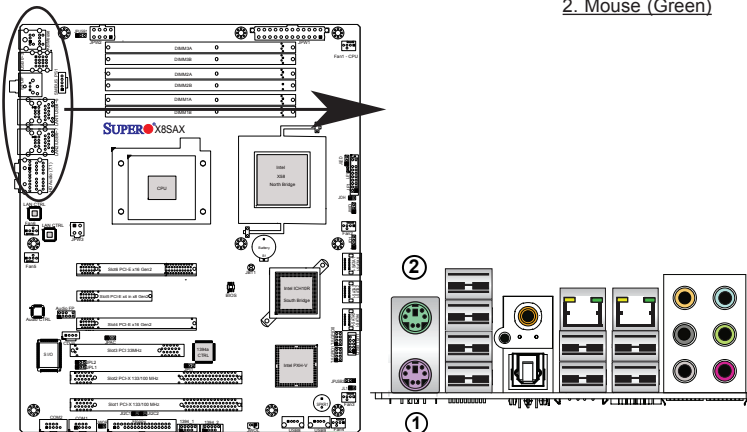

### Universal Serial Bus (USB)

Eight Universal Serial Bus ports (USB 0~3, USB 4/5, USB 6/7) are located on the I/O back panel. USB Ports 4/5 are located below LAN Port1 port. USB 6/7 are below LAN Port2. Additional 4 USB connections (USB 8, USB 9 and USB 10/11) are used to provide front chassis access. USB 8 and USB 9 are Type A Connectors. (USB Cables are not included). See the tables on the right for pin definitions.

Back Panel USB 0~3, 4/5, 6/7 Pin Definitions			
Pin#	Definition	Pin#	Definition
1	+5V	5	+5V
2	USB_PN1	6	USB_PN0
3	USB_PP1	7	USB_PP0
4	Ground	8	Ground

Front Panel USB 8, 9, 10~11 Pin Definitions			
USB 8, 9, 10		USB 11	
Pin #	Definition	Pin #	Definition
1	+5V	6	+5V
2	USB_PN2	7	USB_PN3
3	USB_PP2	8	USB_PP3
4	Ground	9	Ground
5	No Connection	10	Key

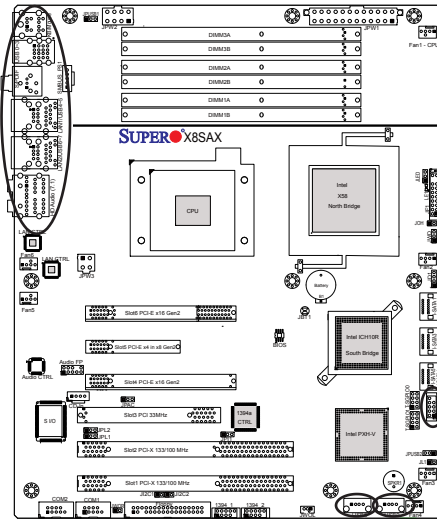

1. Backplane USB 0
2. Backplane USB 1
3. Backplane USB 2
4. Backplane USB 3
5. Backplane USB 4
6. Backplane USB 5
7. Backplane USB 6
8. Backplane USB 7
9. Front Panel USB 8
10. Front Panel USB 9
11. Front Panel USB 10/11

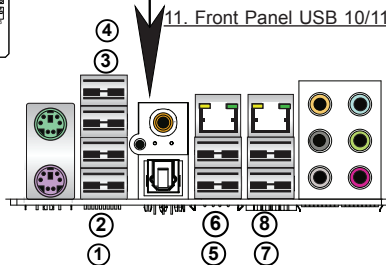

## Ethernet Ports

Two Ethernet ports are located at on the IO backplane above the backpanel USB ports. These ports accept RJ45 type cables. (**Note:** Please refer to the LED Indicator Section for LAN LED information.)

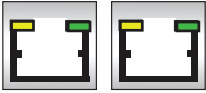

LAN Ports Pin Definition			
Pin#	Definition		
1	P2V5SB	10	SGND
2	TD0+	11	Act LED
3	TD0-	12	P3V3SB
4	TD1+	13	Link 100 LED (Yellow, +3V3SB)
5	TD1-	14	Link 1000 LED (Yellow, +3V3SB)
6	TD2+	15	Ground
7	TD2-	16	Ground
8	TD3+	17	Ground
9	TD3-	18	Ground

(NC: No Connection)

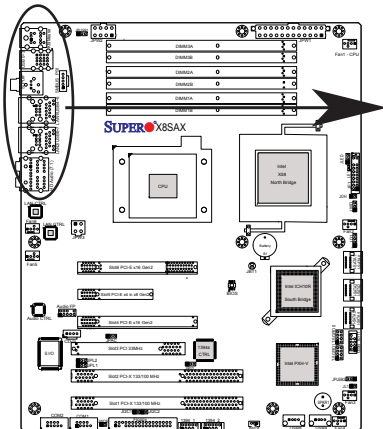

1. LAN1

2. LAN2

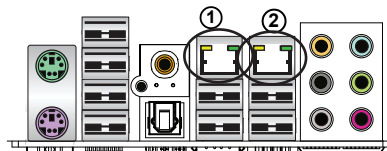

### High Definition Audio (HDA)

The X8SAX/C7X58 features a 7.1+2 Channel High Definition Audio (HDA) codec that provides 10 DAC channels, simultaneously supporting 7.1 sound playback and two channels of independent stereo sound output (multiple streaming) through the front panel stereo out via the front L&R, rear L&R, center and subwoofer speakers. This feature is activated with the software included in the CD-ROM that came with your motherboard. Sound is output through the Line In, Line Out and MIC jacks.

Orange: CEN/LFE

Black: Back Surround

Grey: Side Surround

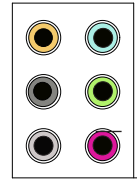

Blue: Line-In

Green: Front

Pink: Mic-In

### CD-Input and FP Audio Headers

A 4-pin CD header is located between PCI Slots 3 & 4. An Auxiliary header is located between Slots 4 & 5 on the motherboard. These headers allow you to use the onboard sound for audio CD playback. Connect an audio cable from your CD drive to the header that fits your cable's connector. Only one CD header can be used at any one time. See the tables at right for pin definitions. Refer to the next page for more info on FP Audio.

CD-In Pin Definitions	
Pin#	Definition
1	Left Stereo Signal
2	Ground
3	Ground
4	Right Stereo Signal

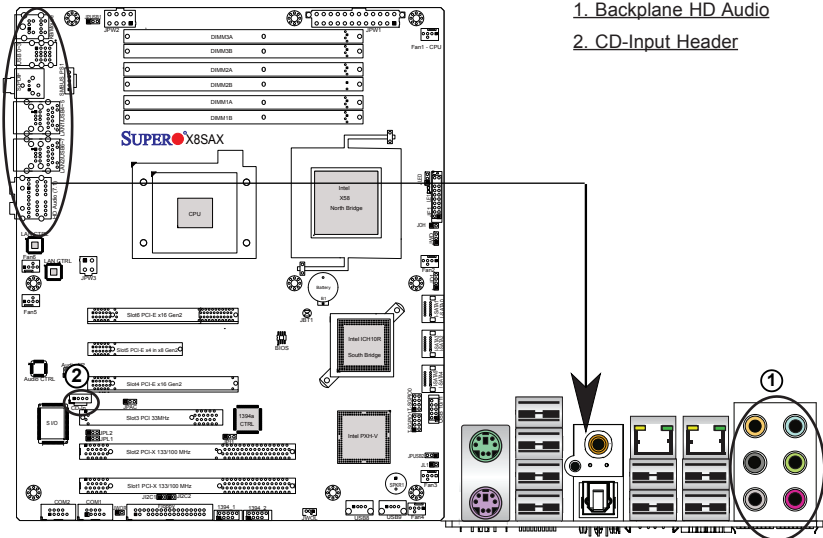

1. Backplane HD Audio

2. CD-Input Header

## Front Panel Audio Control

When front panel headphones are plugged in, the back panel audio output is disabled. This is done through the FP Audio header (Audio FP). If the front panel interface card is not connected to the front panel audio header, jumpers should be installed on the header pin pairs 1-2, 5-6, and 9-10. If these jumpers are not installed, the back panel line out connector will be disabled, and microphone input Pin 1 will be left floating, which can lead to excessive back panel microphone noise and cross talk. See the table at right for pin definitions.

HD Front Panel Audio Pin Definitions	
Pin#	Signal
1	MIC, Left Channel
2	Ground
3	MIC, Right Channel
4	Front Panel Audio-Detect
5	Line Out, Right Channel
6	MIC Jack Detect
7	Front Audio Jack Detect
8	Key
9	Line Out, Left Channel
10	Line Out Jack Detect

## S/PDIF\_Out Connector

An S/PDIF\_Out connector is located next to the Backpanel USB ports on the motherboard. The S/PDIF(Sony/Philips Digital Interface Format) connector is used for transporting stereo digital audio signals. It is commonly used to connect the output of a DVD player to a home theater receiver that supports Dolby Digital or DTS surround sound. The S/PDIF\_Out connector includes the top component (S/PDIF\_RCA) and the bottom component (S/PDIF). See the tables below for pin definitions.

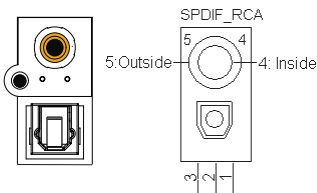

S/PDIF_RCA (Top Component) Pin Definition	
Pin Location	Definition
Outside	Ground
Inside	S/PDIF Signal

S/PDIF (Bottom Component) Pin Definition	
Pin#	Definition
1	Ground
2	Vcc
3	S/PDIF Signal

1. FP Audio
2. S/PDIF-Out Connector

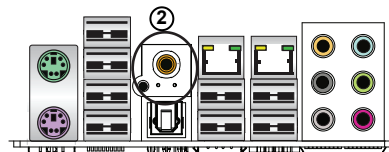
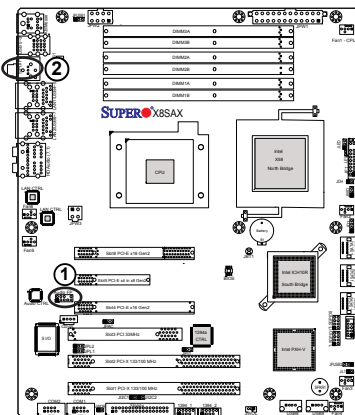

**Serial Ports**

Two COM Port headers are located on the motherboard. See the table on the right for pin definitions.

Serial Port Pin Definitions (COM1/COM2)			
Pin #	Definition	Pin #	Definition
1	CDC	6	DSR
2	RXD	7	RTS
3	TXD	8	CTS
4	DTR	9	RI
5	Ground	10	NC

**Serial ATA Ports**

Six Serial ATA (SATA) ports (SATA0~SATA5) are located next to the ICH10R on the motherboard. These SATA connections are supported by the ICH 10R South Bridge to provide Serial-Link signal transmissions on the motherboard. See the table on the right for pin definitions. Refer to the board layout below for the locations of the headers.

SATA Port Pin Definitions			
Pin#	Definition	Pin	Definition
1	Ground	2	TX+
3	TX-	4	Ground
5	RX-	6	RX+
7	Ground		

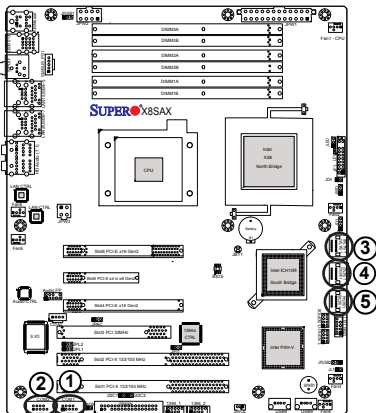

- 1. COM1
- 2. COM2
- 3. SATA 0/1
- 4. SATA 2/3
- 5. 3. SATA 4/5

## Front Control Panel

JF1 contains header pins for various buttons and indicators that are normally located on a control panel at the front of the chassis. These connectors are designed specifically for use with Supermicro server chassis. See the figure below for the descriptions of the various control panel buttons and LED indicators. Refer to the following section for descriptions and pin definitions.

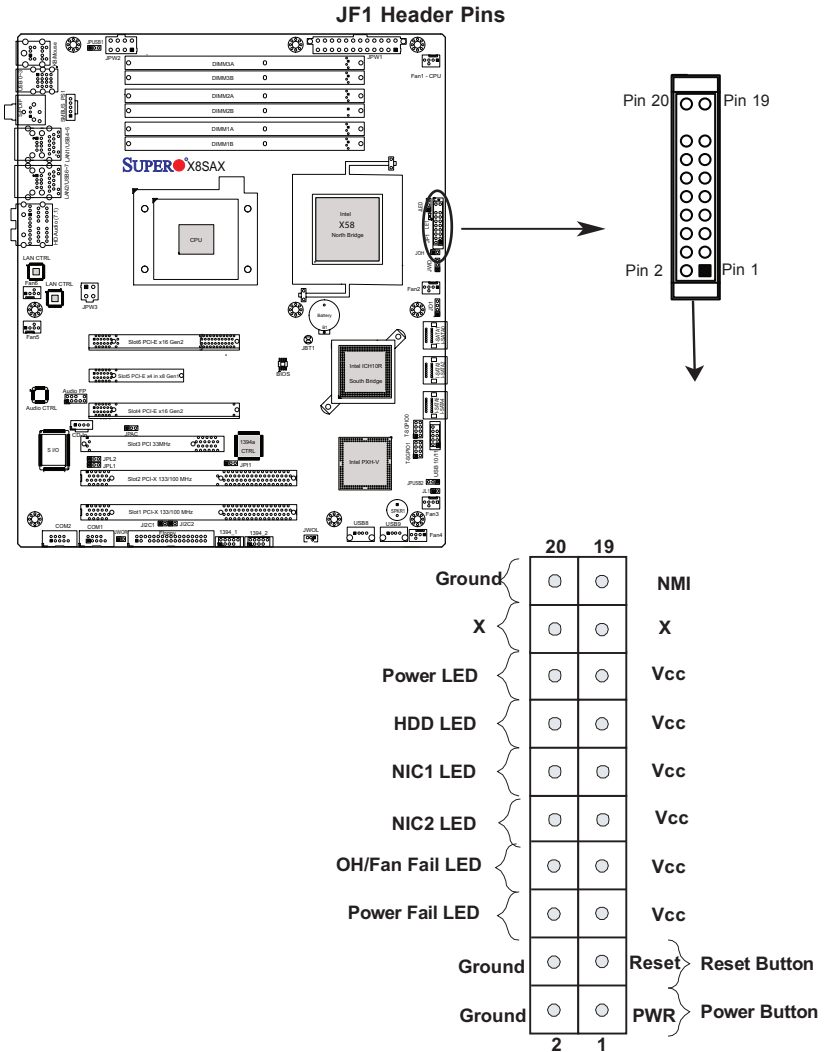

## Front Control Panel Pin Definitions

### NMI Button

The non-maskable interrupt button header is located on pins 19 and 20 of JF1. Refer to the table on the right for pin definitions.

NMI Button Pin Definitions (JF1)	
Pin#	Definition
19	Control
20	Ground

### Power LED

The Power LED connection is located on pins 15 and 16 of JF1. Refer to the table on the right for pin definitions.

Power LED Pin Definitions (JF1)	
Pin#	Definition
15	+5V
16	Ground

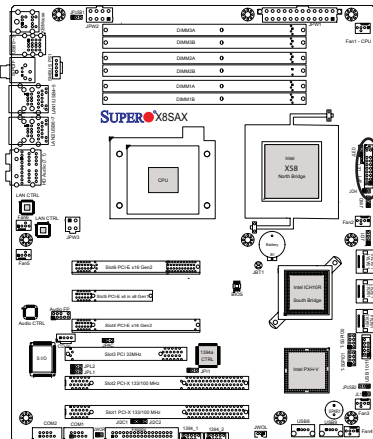

A. NMI

B. PWR LED

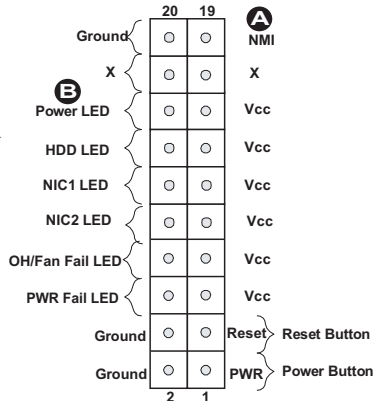

## HDD LED

The HDD LED connection is located on pins 13 and 14 of JF1. Attach a hard drive LED cable here to display disk activity detected on the motherboard's built-in disk controllers (for any hard drive activities on the system, including Serial ATA and IDE). However, any drive activity through an installed third-party add-on card will not be detected. See the table on the right for pin definitions.

HDD LED Pin Definitions (JF1)	
Pin#	Definition
13	+5V
14	HD Active

## NIC1/NIC2 LED Indicators

The NIC (Network Interface Controller) LED connection for LAN port 1 is located on pins 11 and 12 of JF1, and the LED connection for LAN Port 2 is on Pins 9 and 10. Attach the NIC LED cables to display network activity. Refer to the table on the right for pin definitions.

GLAN1/2 LED Pin Definitions (JF1)	
Pin#	Definition
9/11	Vcc
10/12	Ground

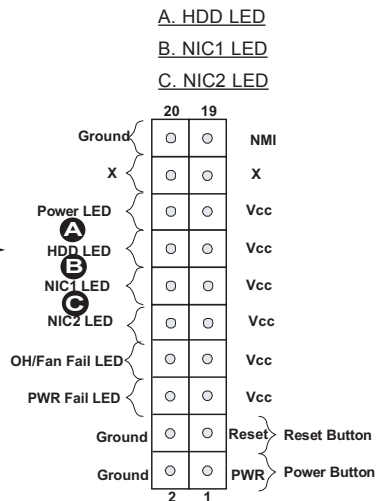
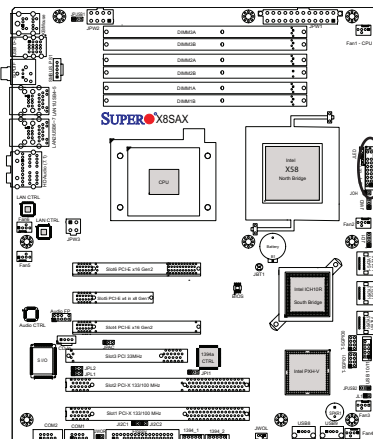

**Overheat (OH)/Fan Fail LED**

Connect an LED cable to the OH/ Fan Fail connection on pins 7 and 8 of JF1 to provide advanced warnings for chassis overheat or fan failure. Refer to the table on the right for pin definitions.

OH/Fan Fail LED Pin Definitions (JF1)	
Pin#	Definition
7	Vcc
8	Ground

OH/Fan Fail Indicator Status	
State	Definition
Off	Normal
On	Overheat
Flashing	Fan Fail

**Power Fail LED**

The Power Fail LED connection is located on pins 5 and 6 of JF1. Refer to the table on the right for pin definitions.

PWR Fail LED Pin Definitions (JF1)	
Pin#	Definition
5	Vcc
6	Ground

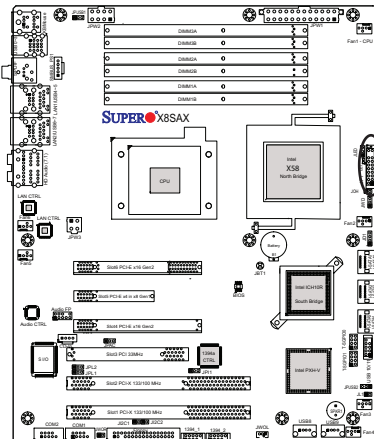

A. OH/Fan Fail LED

B. PWR Supply Fail

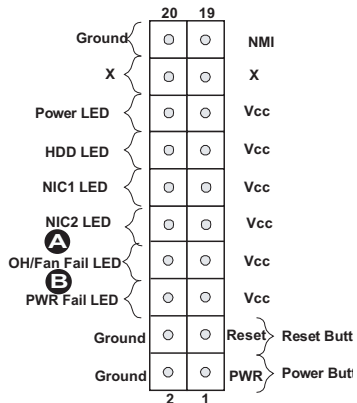

## Reset Button

The Reset Button connection is located on pins 3 and 4 of JF1. Attach it to a hardware reset switch on the computer case to reset the system. Refer to the table on the right for pin definitions.

Reset Button Pin Definitions (JF1)	
Pin#	Definition
3	Reset
4	Ground

## Power Button

The Power Button connection is located on pins 1 and 2 of JF1. Momentarily contacting both pins will power on/off the system. This button can also be configured to function as a suspend button (with a setting in the BIOS - see Chapter 4). To turn off the power in the suspend mode, press the button for at least 4 seconds. Refer to the table on the right for pin definitions.

Power Button Pin Definitions (JF1)	
Pin#	Definition
1	Signal
2	+3V Standby

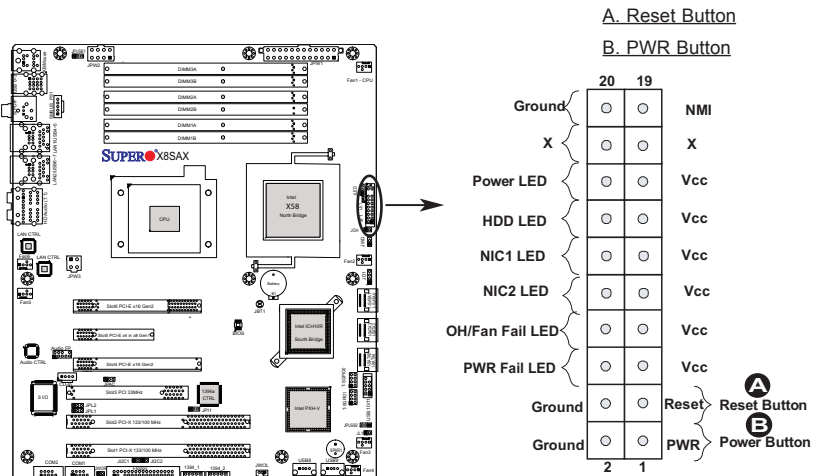

## 2-6 Connecting Cables

This section provides brief descriptions and pin-out definitions for onboard headers and connectors. Be sure to use the correct cable for each header or connector.

- For information on Backpanel USB and Front Panel USB ports, refer to Page 2-9.
- For information on COM Port 1 and COM Port 2, please see Page 2-10.

### ATX Main PWR & CPU PWR Connectors

The 24-pin main power connector (J40) is used to provide power to the motherboard. The 8-pin CPU PWR connector (JPW2) is also required for the processor. These power connectors meet the SSI EPS 12V specification. See the table on the right for pin definitions.

ATX Power 24-pin Connector Pin Definitions (JPW1)			
Pin#	Definition	Pin #	Definition
13	+3.3V	1	+3.3V
14	-12V	2	+3.3V
15	COM	3	COM
16	PS_ON	4	+5V
17	COM	5	COM
18	COM	6	+5V
19	COM	7	COM
20	Res (NC)	8	PWR_OK
21	+5V	9	5VSB
22	+5V	10	+12V
23	+5V	11	+12V
24	COM	12	+3.3V

### 4-Pin Auxiliary Power Connector

In addition to the ATX main power, the 4-pin 12V power connector located at JPW3 is also required to provide power to the South Bridge, North Bridge and all VRMs. See the table on the right for pin definitions.

12V 8-pin Power Connector Pin Definitions (JPW3)		12V 4-pin Power Connector Pin Definitions	
Pins	Definition	Pins	Definition
1 through 4	Ground	1 and 2	Ground
5 through 8	+12V	3 and 4	+12V

(Required)

A. 24-Pin ATX Main PWR

B. 8-Pin Processor PWR

B. 4-Pin Auxiliary PWR

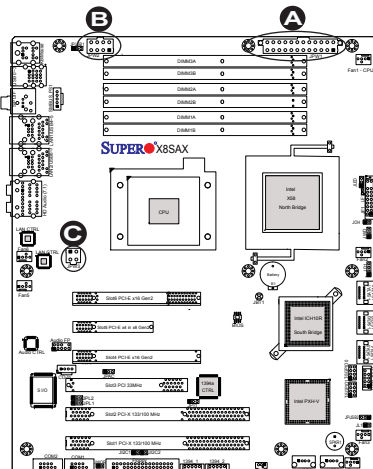

## Fan Headers

The X8SAX/C7X58 has six fan headers (Fan1 ~ Fan6). Fans 2~6 are system cooling fans. Fan 1 is used as a CPU fan. These fans are 4-pin fan headers. However, Pins 1-3 of the fan headers are backward compatible with the traditional 3-pin fans. (**Note:** Please use all 3-pin fans or all 4-pin fans on a motherboard. Please do not use 3-pin fans and 4-pin fans on the same board. The default setting is **Disabled** which allows the onboard fans to run at full speed.) Refer to the table on the right for pin definitions.

Fan Header Pin Definitions	
Pin#	Definition
1	Ground (Black)
2	2.5A/+16V (Red)
3	Tachometer
4	PWM_Control

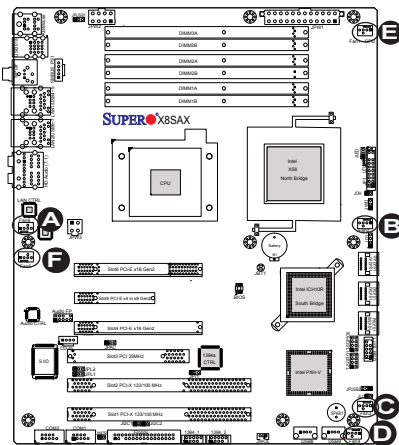

- A. Fan6
- B. Fan2
- C. Fan3
- D. Fan4
- E. Fan1 (CPU Fan)
- F. Fan5

**Internal Buzzer**

The Internal Buzzer (SP1) can be used to provide audible indications for various beep codes. See the table on the right for pin definitions. Refer to the layout below for the locations of the Internal Buzzer (SP1).

Internal Buzzer (SP1) Pin Definition		
Pin#	Definitions	
Pin 1	Pos. (+)	Beep In
Pin 2	Neg. (-)	Alarm Speaker

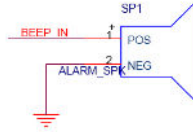

**Speaker**

On the JD1 header, Pins 3~4 are used for internal speaker. Close Pins 3~4 with a cap to use the onboard speaker. If you wish to use an external speaker, close Pins 1~4 with a cable. See the table on the right for pin definitions.

Speaker Connector Pin Definitions	
Pin Setting	Definition
Pins 3~4	Internal Speaker
Pins1~4	External Speaker

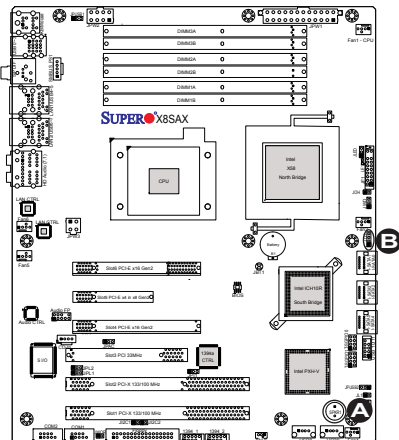

A. Internal Buzzer

B. Speaker

## Overheat/Fan Fail LED (JOH1)

The JOH1 header is used to connect an LED to provide warnings of chassis overheat. This LED will also blink to indicate a fan failure. Refer to the table on right for pin definitions.

Overheat LED Pin Definitions	
Pin#	Definition
1	5vDC
2	OH Active

OH/Fan Fail LED Pin Definitions	
State	Message
Solid	Overheat
Blinking	Fan Fail

## Chassis Intrusion

A Chassis Intrusion header is located at JL1 on the motherboard. Attach the appropriate cable from the chassis to inform you of a chassis intrusion when the chassis is opened.

Chassis Intrusion Pin Definitions (JL1)	
Pin#	Definition
1	Intrusion Input
2	Ground

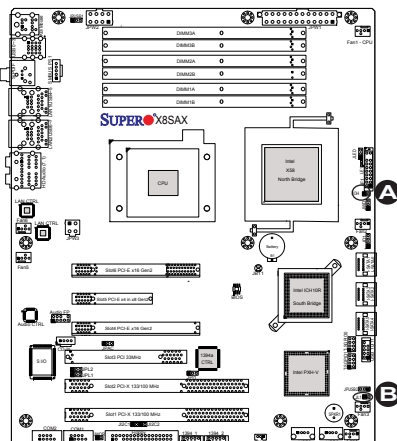

A. Overheat/Fan Fail LED

B. Chassis Intrusion

### Power Supply I<sup>2</sup>C Connector

Power Supply (I<sup>2</sup>C) Connector monitors the status of the power supply, fan and system temperature. See the table on the right for pin definitions.

PWR Supply I <sup>2</sup> C Pin Definitions	
Pin#	Definition
1	Clock
2	Data
3	PWR Fail
4	Ground

### Onboard Power LED

An onboard Power LED header is located at JLED1. This Power LED header is connected to Front Control Panel located at JF1 to indicate the status of system power. See the table on the right for pin definitions.

Onboard PWR LED Pin Definitions	
Pin#	Definition
1	VCC
2	No Connection
3	Connection to PWR LED in JF1

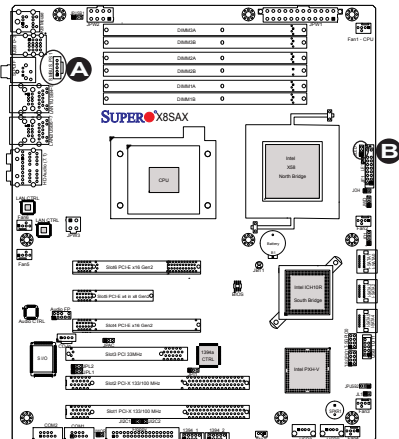

A. PWR SMB

B. PWR LED

### 1394a\_1/1394a\_2 Connections

1394a\_1 and 1394a\_2 provide the IEEE 1394 connections on the motherboard. See the tables on the right for pin definitions.

1394a_1 Pin Definitions			
Pin#	Defin.	Pin#	Defin.
1	PTPA0+	2	PTPA0-
3	GND	4	GND
5	PTPB0+	6	PTPB0-
7	PWR 1394	8	PWR 1394
		10	ZX

J1394a_2 Pin Definitions			
Pin#	Defin.	Pin#	Defin.
1	PTPA1+	2	PTPA1-
3	GND	4	GND
5	PTPB1+	6	PTPB1-
7	PWR 1394	8	PWR 1394
		10	ZY

### T-SGPIO 0/1 Headers

Two T-SGPIO (Serial-Link General Purpose Input/Output) headers are located next to the front USB ports 10/11 on the motherboard. These headers are used to communicate with the enclosure management chip in the system. See the table on the right for pin definitions. Refer to the board layout below for the locations of the headers.

T-SGPIO Pin Definitions			
Pin#	Definition	Pin	Definition
1	NC	2	NC
3	Ground	4	DATA Out
5	Load	6	Ground
7	Clock	8	NC

NC: No Connections

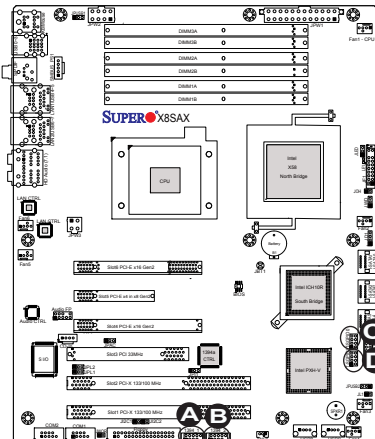

[A. 1394a\\_1](#)

[B. 1394a\\_2](#)

[C. T-SGPIO0](#)

[D. T-SGPIO1](#)

**Wake-On-Ring**

The Wake-On-Ring header is designated JWOR. This function allows your computer to wake up when receiving an incoming call to the modem when in the suspend state. See the table on the right for pin definitions. You must have a Wake-On-Ring card and cable to use this feature.

Wake-On-Ring Pin Definitions (JWOR)	
Pin#	Definition
1	Ground
2	Wake-up

**Wake-On-LAN**

The Wake-On-LAN header is located at JWOL on the motherboard. See the table on the right for pin definitions. (You must also have a LAN card with a Wake-On-LAN connector and cable to use this feature.)

Wake-On-LAN Pin Definitions (JWOL)	
Pin#	Definition
1	+5V Standby
2	Ground
3	Wake-up

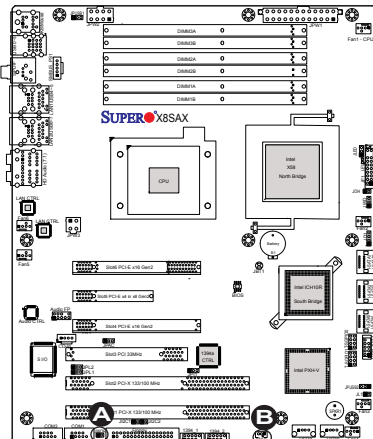

A. WOR

B. WOL

## 2-7 Jumper Settings

### Explanation of Jumpers

To modify the operation of the motherboard, jumpers can be used to choose between optional settings. Jumpers create shorts between two pins to change the function of the connector. Pin 1 is identified with a square solder pad on the printed circuit board.

**Note:** On two pin jumpers, "Closed" means the jumper is on and "Open" means the jumper is off the pins.

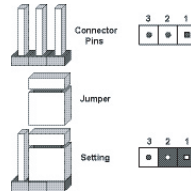

### LAN Port Enable/Disable

JPL1/JPL2 enable or disable LAN Port 1/LAN Port 2 on the motherboard. See the table on the right for jumper settings. The default setting is enabled.

GLAN Enable Jumper Settings	
Pin#	Definition
1-2	Enabled (default)
2-3	Disabled

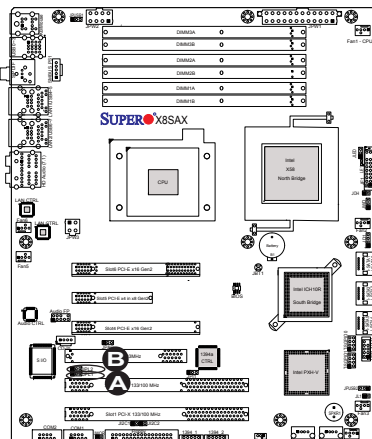

A. LAN Port 1 Enable

B. LAN Port 2 Enable

**CMOS Clear**

JBT1 is used to clear CMOS. Instead of pins, this "jumper" consists of contact pads to prevent accidental clearing of CMOS. To clear CMOS, use a metal object such as a small screwdriver to touch both pads at the same time to short the connection. Always remove the AC power cord from the system before clearing CMOS.

**Note:** For an ATX power supply, you must completely shut down the system, remove the AC power cord and then short JBT1 to clear CMOS. ☒

**Watch Dog Enable/Disable**

Watch Dog is a system monitor that can reboot the system when a software application hangs. Close pins 1-2 to reset the system if an application hangs. Close pins 2-3 to generate a non-maskable interrupt signal for the application that hangs. See the table on the right for jumper settings. Watch Dog must also be enabled in the BIOS.

Watch Dog Jumper Settings (JWD)	
Jumper Setting	Definition
Pins 1-2	Reset (default)
Pins 2-3	NMI
Open	Disabled

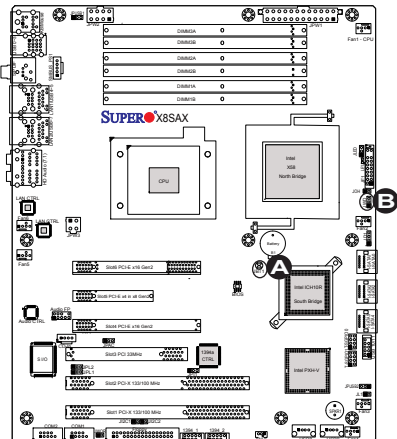

A. Clear CMOS

B. Watch Dog Enable

## SMB to PCI-X/PCI-E Slots Speeds

Use Jumper JI<sup>2</sup>C1 to connect the System Management Bus to the PCI slots, and Jumper JI<sup>2</sup>C2, to the PCI-Exp. slots in order to improve power management for PCI-X and PCI-E slots. The default setting is to close pins 2-3 to disable the function. See the table on the right for jumper settings.

SMBus to PCI-X/PCI-Exp Slots Jumper Settings	
Jumper Setting	Definition
Pins 1-2	Enabled
Pins 2-3 (Default)	Disabled

## IEEE 1394a Enable

JPI1 allows the user to use the onboard IEEE 1394\_1 and 1394\_2 connections. Close Pins 1~2 to use this function. The default setting is Enabled.

1394a Enable Jumper Settings	
Pin#	Definition
1-2	Enabled (default)
2-3	Disabled

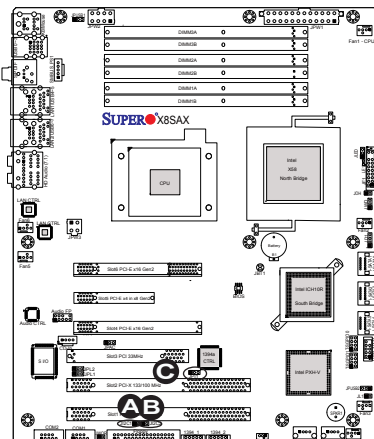

A. JI<sup>2</sup>C1

B. JI<sup>2</sup>C2

C. 1394a 1/2 Enable

**Audio Enable**

JPAC enables or disables the onboard audio connections. See the table on the right for jumper settings. The default setting is Enabled.

Audio Enable (JPAC)	
Pin#	Definition
1-2	Enabled (default)
2-3	Disabled

**USB Wake-Up**

Use JPUSB jumpers to "wake-up" your system by pressing a key on a USB keyboard or clicking the USB mouse of your system. The JPUSB jumpers are used together with the USB Wake-Up feature in the BIOS. Enable both USB jumpers and the USB feature in the BIOS to wake-up your system via USB devices. See the table on the right for jumper settings and jumper connections.

JPUSB1 (BackPanel USB Wake-up)	
Pin#	Definition
1-2	Enabled (default)
2-3	Disabled



**Note:** JPUSB1 is used for Backpanel USB ports #0~7, and JPUSB2 is for Front Panel USB ports #8, #9 and #10~11. The default jumper setting is **Disabled**. However, when the USB function is Enabled in the BIOS, please be sure to remove those USB devices from the USB ports whose USB jumpers are set to Disabled before the system goes into the standby mode.

JPUSB2 (Front Panel USB Wake-up)	
Pin#	Definition
1-2	Enabled (default)
2-3	Disabled

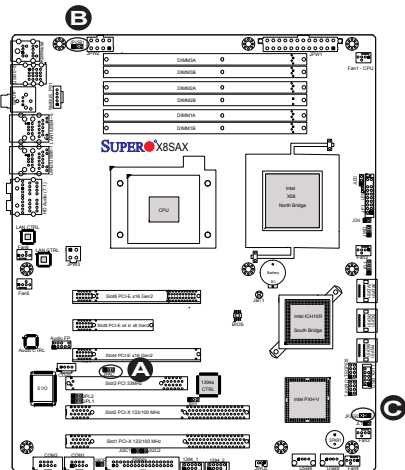

- A. Audio Enable
- B. USB Wake-up (Backpanel)
- C. USB Wake-up (Front Panel)

## 2-8 Onboard Indicators

### Lan Port LEDs

Two LAN ports are located on the I/O Backplane. Each LAN port has two LEDs. The yellow GLAN Activity LED (see below) indicates activity, while the GLAN Link/Speed LED may be green, amber or off to indicate the speed of the connection. See the tables at right for more information.

GLAN Link/Speed LED Indicator	
LED Color	Definition
Off	No Connection or 10 Mbps
Green (On)	100 Mbps
Amber (On)	1 Gbps

GLAN Activity LED Indicator	
Color	Definition
Yellow (Flashing)	ConnectionActive

GLAN Link/Speed LED

GLAN Activity LED

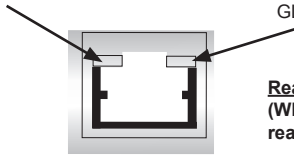

**Rear View**  
(When viewing from the rear side of the chassis.)

### Onboard Power LED

An Onboard Power LED is located at LE1 on the motherboard. When LE1 is on, the AC power cable is connected. Make sure to disconnect the power cable before removing or installing any component. See the layout below for the LED location.

Onboard PWR LED Indicator LED Settings	
LED Color	Definition
Off	System Off
On	System on, or System off and PWR Cable Connected

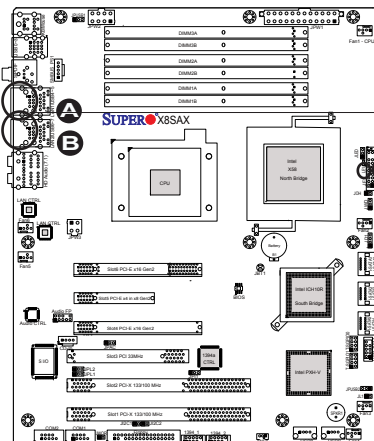

A. LAN Port 1

B. LAN Port 2

C. Onboard Power LED

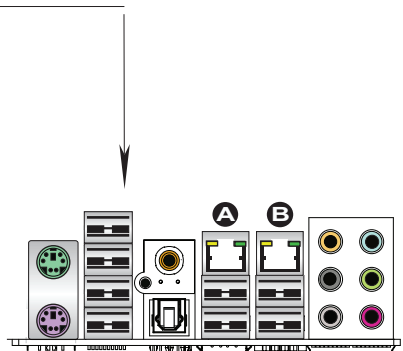

## 2-9 Serial ATA and Floppy Drive Connections

Note the following conditions when connecting the Serial ATA and floppy disk drive cables:

- Be sure to use the correct cable for each connector. Refer to Page 1-1 for cables that came with your shipment.
- A red mark on a wire indicates the location of pin 1.

### SATA Connectors

Six Serial ATA (SATA) connectors (I-SATA 0~5) are located on the motherboard to provide serial link connections. Serial Link connections provide faster data transmission than those of the traditional Parallel ATA. These SATA connectors are supported by the Intel ICH10R Chip (South Bridge). See the table on the right for pin definitions.

SATA Connectors Pin Definitions	
Pin#	Signal
1	Ground
2	SATA_TXP
3	SATA_TXN
4	Ground
5	SATA_RXN
6	SATA_RXP
7	Ground

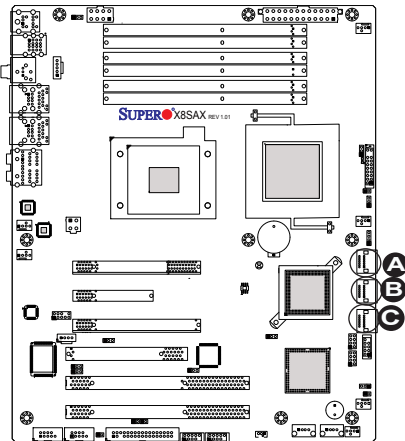

A. I-SATA 0~1

B. I-SATA 2~3

C. I-SATA 4~5

## Floppy Connector

The floppy connector is located near the PCI-X Slot 1 on the motherboard. See the table on the right for pin definitions.



Note the following when connecting the floppy cable:

- The floppy disk drive cable has seven twisted wires.
- A red mark on a wire typically designates the location of pin 1.
- A single floppy disk drive ribbon cable has 34 wires and two connectors to provide for two floppy disk drives. The connector with twisted wires always connects to drive A, and the connector that does not have twisted wires always connects to drive B.

Floppy Drive Connector  
Pin Definitions

Pin#	Definition	Pin #	Definition
1	Ground	2	FDHDIN
3	Ground	4	Reserved
5	Key	6	FDEDIN
7	Ground	8	Index
9	Ground	10	Motor Enable
11	Ground	12	Drive Select B
13	Ground	14	Drive Select B
15	Ground	16	Motor Enable
17	Ground	18	DIR
19	Ground	20	STEP
21	Ground	22	Write Data
23	Ground	24	Write Gate
25	Ground	26	Track 00
27	Ground	28	Write Protect
29	Ground	30	Read Data
31	Ground	32	Side 1 Select
33	Ground	34	Diskette

## A. Floppy

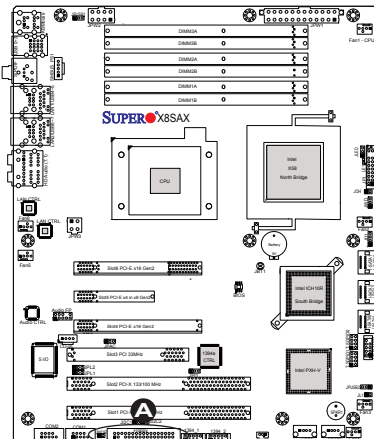

## Notes

## Chapter 3

# Troubleshooting

### 3-1 Troubleshooting Procedures

Use the following procedures to troubleshoot your system. If you have followed all of the procedures below and still need assistance, refer to the 'Technical Support Procedures' and/or 'Returning Merchandise for Service' section(s) in this chapter. Always disconnect the AC power cord before adding, changing or installing any hardware components.

#### Before Power On

1. Make sure that the Standby PWR LED (LE1) is not lit. (**Note:** If LE1 is on, the onboard power is on. Be sure to unplug the power cable before installing or removing the components.)
2. Make sure that there are no short circuits between the motherboard and chassis.
3. Disconnect all ribbon/wire cables from the motherboard, including those for the keyboard and mouse. Also, be sure to remove all add-on cards.
4. Install a CPU and heatsink (be sure that it is fully seated) and then connect the chassis speaker and the power LED to the motherboard. Check all jumper settings as well.

#### No Power

1. Make sure that there are no short circuits between the motherboard and chassis.
2. Make sure that all jumpers are set to their default positions.
3. Check if the 115V/230V switch on the power supply is properly set.
4. Turn the power switch on and off to test the system.
5. The battery on your motherboard may be old. Check to make sure that it still supplies ~3VDC. If it does not, replace it with a new one.

#### No Video

1. If the power is on, but you have no video--in this case, you will need to remove all the add-on cards and cables first.

2. Use the speaker to determine if any beep codes exist. (Refer to Appendix A for details on beep codes.)
3. Remove all memory modules and turn on the system. (If the alarm is on, check the specs of memory modules, reset the memory or try a different one.)

## Memory Errors

1. Make sure that the DIMM modules are properly installed and fully seated in the slots.
2. You should be using unbuffered ECC or non-ECC DDR3 (1.5V)1333/1066/800 MHz memory (See the next page). Also, it is recommended that you use the memory modules of the same type and speed for all DIMMs in the system.
3. Check for bad DIMM modules or slots by swapping modules between slots to see if you can locate the faulty modules.
4. Check the power supply voltage 115V/230V switch.

## Losing the System's Setup Configuration

1. Please be sure to use a high quality power supply. A poor quality power supply may cause the system to lose the CMOS setup information. Refer to Section 1-5 for details on recommended power supplies.
2. The battery on your motherboard may be old. Check to verify that it still supplies ~3VDC. If it does not, replace it with a new one.
3. If the above steps do not fix the Setup Configuration problem, contact your vendor for repairs.

## 3-2 Technical Support Procedures

Before contacting Technical Support, please make sure that you have followed all the steps listed below. Also, Note that as a motherboard manufacturer, Supermicro does not sell directly to end users, so it is best to first check with your distributor or reseller for troubleshooting services. They should know of any possible problem(s) with the specific system configuration that was sold to you.

1. Please go through the 'Troubleshooting Procedures' and 'Frequently Asked Question' (FAQ) sections in this chapter or see the FAQs on our website (<http://www.supermicro.com/support/faqs/>) before contacting Technical Support.
2. BIOS upgrades can be downloaded from our website at (<http://www.supermicro.com/support/bios/>).



**Note:** Not all BIOS can be flashed. Some cannot be flashed; it depends on the modifications to the boot block code.

3. If you've followed the instructions above to troubleshoot your system, and still cannot resolve the problem, then contact Supermicro's technical support and provide them with the following information:

- Motherboard model and PCB revision number
- BIOS release date/version (this can be seen on the initial display when your system first boots up)
- System configuration

An example of a Technical Support form is on our website at <http://www.supermicro.com/support/contact.cfm>.

4. Distributors: For immediate assistance, please have your account number ready when placing a call to our technical support department. We can be reached by e-mail at [support@supermicro.com](mailto:support@supermicro.com), by phone at: (408) 503-8000, option 2, or by fax at (408)503-8019.

### 3-3 Frequently Asked Questions

**Question:** What type of memory does my motherboard support?

**Answer:** The X8SAX/C7X58 supports up to 24 GB of **unbuffered** ECC or non-ECC (1.5V) DDR3 1333/1066/800 MHz, two-way interleaved or non-interleaved SDRAM. Additionally, the C7X58 also supports 1600 XMP memory when an Extreme Edition CPU is installed. See Section 2-4 for details on installing memory.



**Note:** Please enable XMP under Performance Tuning Mode in the BIOS to enable 1600 XMP operation on the C7X58 (See page 4-11). You must have an Extreme Edition CPU installed for this feature to work. Otherwise, the system will fall back to a lower bus speed regardless of the BIOS settings.

**Question:** I installed 1333/1066 MHz memory, why doesn't my motherboard (X8SAX, C7X58, X8ST3-F/E or X8STi family) run the memory at 1333/1066 MHz?

The memory speed depends on the installed CPUs QPI rating. Please check your CPU specifications. For example, to support 1333 MHz memory, the CPU's QPI should be 6.4GT/S. A lower QPI number means that it will support slower memory. More information may be found at [www.intel.com](http://www.intel.com).

**Question:** When I plug in my 1600 MHz XMP DDR3 memory into the X8SAX or C7X58 motherboard, it only shows that it's running at 1333MHz or 1066 MHz. How can I make it work at 1600MHz?

**Answer:** The X8SAX motherboard does not support 1600MHz XMP memory. Therefore, it will only support up to 1066/1333MHz.

On the C7X58 motherboard, please enable 1600MHz XMP mode in the BIOS:

Enter BIOS setup, go to Advanced -> Advanced Chipset Control -> QPI & IMC Configuration -> Performance Tuning Mode, then select "XMP" = 1600MHz



**Note:** If the C7X58 motherboard detects that the memory installed is not suited for 1600MHz XMP operation, the BIOS activates a protection routine to lower its clock speed to 1066MHz or 1333MHz automatically. This is done to protect the system so it can still boot using the proper clock speed.

**Question:** How do I update my BIOS?

**Answer:** It is recommended that you do not upgrade your BIOS if you are not experiencing any problems with your system. Updated BIOS files are located on our web site at <http://www.supermicro.com/support/bios/>. Please check our BIOS warning message and the information on how to update your BIOS on our web site. Select your motherboard model and download the BIOS (.rom) file to your computer. Also, check the current BIOS revision and make sure that it is newer than your BIOS before downloading. You may choose the zip file or the .exe file. If you choose the zipped BIOS file, please unzip the BIOS file onto a bootable device or a USB pen/thumb drive. To flash the BIOS, run the batch file named "ami.bat" with the new BIOS ROM file from your bootable device or USB pen/thumb drive. Use the following format:

```
F:\> ami.bat BIOS-ROM-filename.xxx <Enter>
```



**Notes:** Always use the file named "ami.bat" to update the BIOS and insert a space between "ami.bat" and the filename. The BIOS-ROM-filename will bear the motherboard name (i.e., X8SAX) and build version as the extension. For example, "X8SAX0.115".

When completed, your system will automatically reboot. If you choose the .exe file, please run the .exe file under Windows to create the BIOS flash floppy disk. Insert the floppy disk into the system you wish to flash the BIOS. Then, boot the system to the floppy disk. The BIOS utility will automatically flash the BIOS without any prompts. Please note that this process may take a few minutes to complete. Do not be concerned if the screen is paused for a few minutes.



**Warning:** Do not shut down or reset the system while updating the BIOS to prevent possible system boot failure!

When the BIOS flashing screen is completed, the system will reboot and will show “Press F1 or F2”. At this point, you will need to load the BIOS defaults. Press <F1> to go to the BIOS setup screen, and press <F9> to load the default settings. Next, press <F10> to save and exit. The system will then reboot.



**Note:** The SPI BIOS chip installed on this motherboard is not removable. To repair or replace a damaged BIOS chip, please send your motherboard to RMA at Supermicro for service.

**Question: I think my BIOS is corrupted. How can I recover my BIOS?**

**Answer:** Please see Appendix D, BIOS Recovery for detailed instructions.

**Question: What’s on the CD that came with my motherboard?**

**Answer:** The supplied compact disc has quite a few drivers and programs that will greatly enhance your system. We recommend that you review the CD and install the applications you need. Applications on the CD include chipset drivers for Windows, security and audio drivers.

**Question: How do I handle used batteries?**

**Answer:** Please handle used batteries carefully. Do not damage the battery in any way; a damaged battery may release hazardous materials into the environment. Do not discard a used battery in the garbage or a public landfill. Please comply with the regulations set up by your local hazardous waste management agency to dispose of your used battery properly.

### 3-4 Returning Merchandise for Service

A receipt or copy of your invoice marked with the date of purchase is required before any warranty service will be rendered. You can obtain service by calling your vendor for a Returned Merchandise Authorization (RMA) number. When returning to the manufacturer, the RMA number should be prominently displayed on the outside of the shipping carton, and mailed prepaid or hand-carried. Shipping and handling charges will be applied for all orders that must be mailed when service is complete. For faster service, RMA authorizations may be requested online (<http://www.supermicro.com/support/rma>).

This warranty only covers normal consumer use and does not cover damages incurred in shipping or from failure due to the alteration, misuse, abuse or improper maintenance of products.

During the warranty period, contact your distributor first for any product problems.

## Notes

---

## Chapter 4

### BIOS

#### 4-1 Introduction

This chapter describes the AMI BIOS Setup Utility for the X8SAX-C7X58. The AMI ROM BIOS is stored in a Flash EEPROM and can be easily updated. This chapter describes the basic navigation of the AMI BIOS Setup Utility setup screens.

#### Starting BIOS Setup Utility

To enter the AMI BIOS Setup Utility screens, press the <Delete> key while the system is booting up.



**Note:** In most cases, the <Delete> key is used to invoke the AMI BIOS setup screen. There are a few cases when other keys are used, such as <F1>, <F2>, etc.

Each main BIOS menu option is described in this manual. The Main BIOS setup menu screen has two main frames. The left frame displays all the options that can be configured. Grayed-out options cannot be configured. Options in blue can be configured by the user. The right frame displays the key legend. Above the key legend is an area reserved for a text message. When an option is selected in the left frame, it is highlighted in white. Often a text message will accompany it. (**Note:** the AMI BIOS has default text messages built in. Supermicro retains the option to include, omit, or change any of these text messages.)

The AMI BIOS Setup Utility uses a key-based navigation system called "hot keys". Most of the AMI BIOS setup utility "hot keys" can be used at any time during the setup navigation process. These keys include <F1>, <F10>, <Enter>, <ESC>, arrow keys, etc.



**Note:** Options printed in **Bold** are default settings.

#### How To Change the Configuration Data

The configuration data that determines the system parameters may be changed by entering the AMI BIOS Setup utility. This Setup utility can be accessed by pressing <Del> at the appropriate time during system boot.

## How to Start the Setup Utility

Normally, the only visible Power-On Self-Test (POST) routine is the memory test. As the memory is being tested, press the <Delete> key to enter the main menu of the AMI BIOS Setup Utility. From the main menu, you can access the other setup screens. An AMI BIOS identification string is displayed at the left bottom corner of the screen, below the copyright message.



**Warning!** Do not upgrade the BIOS unless your system has a BIOS-related issue. Flashing the wrong BIOS can cause irreparable damage to the system. In no event shall Supermicro be liable for direct, indirect, special, incidental, or consequential damages arising from a BIOS update. If you have to update the BIOS, do not shut down or reset the system while the BIOS is updating. This is to avoid possible boot failure.

## 4-2 Main Setup

When you first enter the AMI BIOS Setup Utility, you will enter the Main setup screen. You can always return to the Main setup screen by selecting the Main tab on the top of the screen. The Main BIOS Setup screen is shown below.

BIOS SETUP UTILITY	
Main	Advanced Security Boot Exit
<b>System Overview</b>	
System Time	[08:20:40]
System Date	[Tue 06/14/2010]
<b>Supermicro X8SAX/C7X58</b>	
Version	: 1.1a
Build Date	: 04/29/10
<b>Processor</b>	
Intel(R) Core(TM) i7 CPU	975 @ 3.33GHz
Speed	: 3333MHz
Physical Count	: 1
Logical Count	: 8
<b>System Memory</b>	
Populated Size	: 2048MB
Available Size	: 2048MB
Use [ENTER], [TAB] or [SHIFT-TAB] to select a field.  Use [+] or [-] to configure system time.  ← → Select Screen ↑↓ Select Item +- Change Field Tab Select Field F1 General Help F10 Save and Exit ESC Exit	
vXX.XX (C) Copyright 1985-2009, American Megatrends, Inc.	

**System Overview:** The following BIOS information will be displayed:

### **System Time/System Date**

Use this option to change the system time and date. Highlight *System Time* or *System Date* using the arrow keys. Enter new values through the keyboard. Press the <Tab> key or the arrow keys to move between fields. The date must be entered in Day MM/DD/YY format. The time is entered in HH:MM:SS format. (**Note:** The time is in the 24-hour format. For example, 5:30 P.M. appears as 17:30:00.)

Supermicro X8SAX/C7X58

Version

Build Date

### **Processor**

The AMI BIOS will automatically display the status of processor as shown below:

Type of Processor

Speed

Physical Count

Logical Count

### **System Memory**

This displays the size of memory available in the system:

Populated Size

Available Size

## 4-3 Advanced Setup Configurations

Use the arrow keys to select Boot Setup and hit <Enter> to access the submenu items:

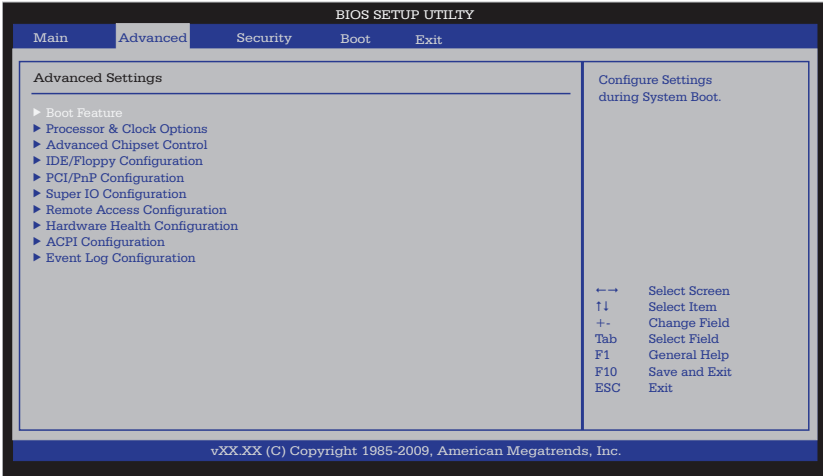

### ▶ BOOT Feature

#### Quick Boot

If Enabled, this option will skip certain tests during POST to reduce the time needed for system boot. The options are **Enabled** and Disabled.

#### Quiet Boot

This option allows the bootup screen options to be modified between POST messages or the OEM logo. Select Disabled to display the POST messages. Select Enabled to display the OEM logo instead of the normal POST messages. The options are **Enabled** and Disabled.

#### AddOn ROM Display Mode

This sets the display mode for Option ROM. The options are **Force BIOS** and Keep Current.

#### Bootup Num-Lock

This feature selects the Power-on state for Numlock key. The options are Off and **On**.

#### PS/2 Mouse Support

This feature enables support for the PS/2 mouse. The options are Disabled, Enabled and **Auto**.

**Wait For 'F1' If Error**

This forces the system to wait until the 'F1' key is pressed if an error occurs. The options are Disabled and **Enabled**.

**Hit 'Del' Message Display**

This feature displays "Press DEL to run Setup" during POST. The options are **Enabled** and Disabled.

**Watch Dog Function**

If enabled, the Watch Dog Timer will allow the system to reboot when it is inactive for more than 5 minutes. The options are Enabled and **Disabled**.

**Power Button Function**

This setting allows you to decide if the power button will instantly turn the system off, or wait 4 seconds to turn off while the button is depressed. The options are 4 Seconds Override and **Instant Off**.

**Restore on AC Power Loss**

Use this feature to set the power state after a power outage. Select Power-Off for the system power to remain off after a power loss. Select Power-On for the system power to be turned on after a power loss. Select Last State to allow the system to resume its last state before a power loss. The options are Power-On, Power-Off and **Last State**.

**Interrupt 19 Capture**

Interrupt 19 is the software interrupt that handles the boot disk function. When this item is set to Enabled, the ROM BIOS of the host adaptors will "capture" Interrupt 19 at boot and allow the drives that are attached to these host adaptors to function as bootable disks. If this item is set to Disabled, the ROM BIOS of the host adaptors will not capture Interrupt 19, and the drives attached to these adaptors will not function as bootable devices. The options are **Enabled** and Disabled.

**EUP Support**

EUP, or Energy Using Product is a European energy-saving specification that sets a standard on the maximum total power consumption on electrical products. Select Enabled to activate EUP support, select **Disabled** for normal S5 sleep mode (system wakeup capability).

## ►Processor & Clock Options



**Warning:** Take Caution when changing the Advanced settings. An incorrect value, a very high DRAM frequency or incorrect DRAM timing may cause system to become unstable. When this occurs, revert to the default setting.

### CPU Ratio

This feature allows the user to use the CPU clock multiplier to multiply CPU speed in order to enhance performance. Select Manual to Manually set the multiplier setting. Select Auto for the BIOS to automatically select the CPU multiplier setting for your system. The options are **Auto** and Manual.

### Clock Spread Spectrum

Select Enable to use the feature of Clock Spectrum, which will allow the BIOS to monitor and attempt to reduce the level of Electromagnetic Interference caused by the components whenever needed. Select Disabled to enhance system stability. The options are **Disabled** and Enabled.

### Hardware Prefetcher (Available when supported by the CPU)

If set to Enabled, the hardware pre fetcher will pre fetch streams of data and instructions from the main memory to the L2 cache in the forward or backward manner to improve CPU performance. The options are Disabled and **Enabled**.

### Adjacent Cache Line Prefetch (Available when supported by the CPU)

The CPU fetches the cache line for 64 bytes if this option is set to Disabled. The CPU fetches both cache lines for 128 bytes as comprised if **Enabled**.

### MPS and ACPI MADT Ordering

Choose the method of ordering for the Multiple APIC Description Table (MADT). Select Modern Ordering for Microsoft Windows XP or later, Select Legacy Ordering for Microsoft Windows 2000 or earlier. The options are **Modern Ordering** and Legacy Ordering.

### Intel® Virtualization Technology (Available when supported by the CPU)

Select Enabled to use the feature of Virtualization Technology to allow one platform to run multiple operating systems and applications in independent partitions, creating multiple "virtual" systems in one physical computer. The options are **Enabled** and Disabled. **Note:** If there is any change to this setting, you will need to power off and restart the system for the change to take effect. Please refer to Intel's web site for detailed information.

**Execute-Disable Bit Capability (Available when supported by the OS and the CPU)**

Set to Enabled to enable the Execute Disable Bit which will allow the processor to designate areas in the system memory where an application code can execute and where it cannot, thus preventing a worm or a virus from flooding illegal codes to overwhelm the processor or damage the system during an attack. The default is **Enabled**. (Refer to Intel and Microsoft Web Sites for more information.)

**Intel AES-NI (When supported by the CPU)**

Intel® AES instructions are a new set of instructions available beginning with the the all new 2010 Intel® Core™ processor family based on the 32nm Intel® microarchitecture. These instructions enable fast and secure data encryption and decryption, using the Advanced Encryption Standard (AES). The options are Disabled and **Enabled**.

**Simultaneous Multi-Threading (Available when supported by the CPU)**

Set to Enabled to use the Hyper-Threading Technology, which will result in increased CPU performance. The options are Disabled and **Enabled**.

**Active Processor Cores**

Set to Enabled to use a processor's Second Core and beyond. (Please refer to Intel's web site for more information.) The options are **All**, 1 and 2.

**Intel® EIST Technology**

EIST (Enhanced Intel SpeedStep Technology) allows the system to automatically adjust processor voltage and core frequency in an effort to reduce power consumption and heat dissipation. **Please refer to Intel's web site for detailed information.** The options are Disable (Disable GV3), and **Enable (Enable GV3)**.

**Intel® Turbo Boost (Available if Intel® EIST technology is Enabled)**

This feature allows processor cores to run faster than marked frequency in specific conditions. The options are Disabled and **Enabled**.

**C1E Support**

Select Enabled to use the "Enhanced Halt State" feature. C1E significantly reduces the CPU's power consumption by reducing the CPU's clock cycle and voltage during a "Halt State." The options are Disabled and **Enabled**.

**Intel C-STATE Tech**

If enabled, C-State is set by the system automatically to either C2, C3 or C4 state. The options are Disabled and **Enabled**.

### **C-State package limit setting**

If set to Auto, the AMI BIOS will automatically set the limit on the C-State package register. The options are **Auto**, C1, C3, C6 and C7.

### **C1 Auto Demotion**

When enabled, the CPU will conditionally demote C3, C6 or C7 requests to C1 based on un-core auto-demote information. The options are Disabled and **Enabled**.

### **C3 Auto Demotion**

When enabled, the CPU will conditionally demote C6 or C7 requests to C3 based on un-core auto-demote information. The options are Disabled and **Enabled**.

### **ACPI T State**

This feature Enables the ACPI throttling support for the processor to save power. The options are **Disabled** and Enabled.

### **DCA Technology**

This feature accelerates the performance of TOE devices. **Note:** A TOE device is a specialized, dedicated processor that is installed on an add-on card or a network card to handle some or all packet processing of this add-on card. For this motherboard, the TOE device is built inside the ESB 2 South Bridge chip. This feature is supported only by some types of processors. The options are **Enabled** and Disabled.

### **DCA Prefetch Delay**

A DCA Prefetch is used with TOE components to prefetch data in order to shorten execution cycles and maximize data processing efficiency. Prefetching too frequently can saturate the cache directory and delay necessary cache accesses. This feature reduces or increases the frequency the system prefetches data. The options are [8], [16], **[32]**, [40], [48], [56], [64], [72], [80], [88], [96], [104], [112], [120]

## **►Advanced Chipset Control**

The items included in the Advanced Settings submenu are listed below.

## **►QPI and IMC Configuration**

QuickPath Interconnect (QPI) is the connection between the CPU and the motherboard's I/O hub. Use this feature to modify speed and power management settings.

### **QPI Links Speed**

Use this feature to select QPI data transfer speed. The options are Slow-mode, and **Full Speed**.

### **QPI Frequency**

Use this option to set the QPI frequency. The options are **Auto**, 4.800 GT, 5.866 GT, and 6.400 GT.

### **QPI L0s and L1**

QuickPath Interconnect (QPI) offers three power states called L0, L0s and L1:

L0 is a normal operational state where data and control packets can be transmitted and received. All power management states are entered from this state.

L0s is intended as a power saving state. It allows a link to quickly enter and recover from a power saving state without going through recovery.

L1 is a power saving state that allows an additional power saving over L0s, but with additional resume (wake-up) latency.

Select Enabled to activate QPI power saving (L0s and L1 are automatically selected by the motherboard), select Disabled for normal operational state without any power-saving function. The options are Disabled and **Enabled**.

### **Memory Frequency**

Use this option to force the system memory to run at a different frequency than the default frequency. The available options are **Auto**, Force DDR-800, Force DDR-1066, and Force DDR-1333.

### **Memory Mode**

The options are **Independent**, Channel Mirror, Lockstep and Sparing.

Independent - All DIMMs are available to the operating system.

Channel Mirror - The motherboard maintains two identical copies of all data in memory for redundancy.

Lockstep - The motherboard uses two areas of memory to run the same set of operations in parallel.

Sparing - Memory sparing occurs when on-demand inactive memory is automatically activated by the system to temporarily replace failed memory until a service action can be performed (supported only on 2010 Intel® Core™ processor family based on the 32nm Intel® microarchitecture).

### **Demand Scrubbing**

Demand Scrubbing is a process that allows the CPU to correct correctable memory errors found on a memory module. When the CPU or I/O issues a demand-read command, and the read data from memory turns out to be a correctable error, the error is corrected and sent to the requestor (the original source). Memory is updated as well. Select Enabled to use Demand Scrubbing for ECC memory correction. The options are Enabled and **Disabled**.

### **Patrol Scrubbing**

Patrol Scrubbing is a process that allows the CPU to correct correctable memory errors detected on a memory module and send the correction to the requestor (the original source). When this item is set to Enabled, the North Bridge will read and write back one cache line every 16K cycles, if there is no delay caused by internal processing. By using this method, roughly 64 GB of memory behind the North Bridge will be scrubbed every day. The options are Enabled and **Disabled**.

### **Throttling - Closed Loop**

Throttling improves reliability and reduces power in the processor by automatic voltage control during processor idle states. Available options are Disabled and **Enabled**.

### **Performance Tuning Mode (Available on the C7X58 only, when both XMP memory and an Extreme Edition CPU are installed.)**

This item allows the user to choose the Intel Extreme Memory Profile (XMP) Specification which enables DDR3 memory to operate beyond the standard JEDEC SPD specification. Select XMP for 1600 MHz XMP memory operation and better system performance. Otherwise, leave this setting on **Auto**.

### **HDA Controller**

Select Enabled to enable the High-Definition Audio controller. The options are **Enabled** and Disabled.

### **Intel VT-d**

Select Enabled to enable Intel's Virtualization Technology support for Direct I/O VT-d by reporting the I/O device assignments to VMM through the DMAR ACPI Tables. This feature offers fully-protected I/O resource-sharing across the Intel platforms, providing the user with greater reliability, security and availability in networking and data-sharing. The settings are Enabled and **Disabled**.

### **SR-IOV Support**

Enable this item to support Single Root I/O Virtualization and Sharing (SR-IOV). The options are **Disabled** and Enabled.

### **Intel I/OAT**

The Intel I/OAT (I/O Acceleration Technology) significantly reduces CPU overhead by leveraging CPU architectural improvements, freeing resources for more other tasks. The options are Disabled and **Enabled**.

### Active State Power Management

Select Enabled to start Active-State Power Management for signal transactions between L0 and L1 Links on the PCI Express Bus. This maximizes power-saving and transaction speed. The options are Enabled and **Disabled**.

### Route Port 80h Cycles to

This feature allows the user to decide which bus to send debug information to. The options are Disabled, **PCI** and LPC.

### Extend PCI Hole

Select Enabled when using a 64-bit Operating System. The options are Disabled and **Enabled**.

### USB Functions

This feature allows the user to decide the number of onboard USB ports to be enabled. The Options are: Disabled, 2 USB ports, 4 USB ports, 6 USB ports, 8 USB ports, 10 USB ports and **12 USB Ports**.

### USB 2.0 Controller

Select Enabled to activate the onboard USB 2.0 controller. The options are **Enabled** and Disabled.

### Legacy USB Support

Select Enabled to use Legacy USB devices. If this item is set to Auto, Legacy USB support will be automatically enabled if a legacy USB device is installed on the motherboard, and vice versa. The settings are Disabled, Enabled and **Auto**.

## ►IDE / Floppy Configuration

When this submenu is selected, the AMI BIOS automatically detects the presence of the IDE Devices and displays the following items:

### Floppy A

This feature allows the user to select the type of floppy drive connected to the system. The options are Disabled, 360KB 5 1/4", 1.2MB 5 1/4", 720KB 3 1/2", **1.44MB 3 1/2"** and 2.88MB 3 1/2".

### SATA#1 Configuration

If Compatible is selected, it sets SATA#1 to legacy compatibility mode, while selecting Enhanced sets SATA#1 to native SATA mode. The options are Disabled, Compatible, **Enhanced**.

### **Configure SATA#1 as**

This feature allows the user to select the drive type for SATA#1. The options are **IDE**, **RAID** and **AHCI**.

### **ICH RAID CodeBase** (Available if RAID is selected above)

Select Intel to enable the Intel SATA Host RAID Utility. Select Adaptec to use the Adaptec Host RAID Utility. The options are **Intel** and **Adaptec**.

### **SATA#2 Configuration** (Available if IDE is enabled under "Configure SATA#1 as" above)

Selecting Enhanced will set SATA#2 to native SATA mode. The options are Disabled, **Enhanced**

### **IDE Detect Timeout (sec)**

Use this feature to set the time-out value for the BIOS to detect the ATA, ATAPI devices installed in the system. The options are 0 (sec), 5, 10, 15, 20, 25, 30, and **35**.

### **Primary IDE Master/Slave, Secondary IDE Master/Slave, Third IDE Master, and Fourth IDE Master**

These settings allow the user to set the parameters of Primary IDE Master/Slave, Secondary IDE Master/Slave, Third and Fourth IDE Master slots. Hit <Enter> to activate the following submenu screen for detailed options of these items. Set the correct configurations accordingly. The items included in the submenu are:

#### **Type**

Select the type of device connected to the system. The options are Not Installed, **Auto**, CD/DVD and ARMD.

#### **LBA/Large Mode**

LBA (Logical Block Addressing) is a method of addressing data on a disk drive. In the LBA mode, the maximum drive capacity is 137 GB. For drive capacities over 137 GB, your system must be equipped with a 48-bit LBA mode addressing. If not, contact your manufacturer or install an ATA/133 IDE controller card that supports 48-bit LBA mode. The options are Disabled and **Auto**.

#### **Block (Multi-Sector Transfer)**

Block Mode boosts the IDE drive performance by increasing the amount of data transferred. Only 512 bytes of data can be transferred per interrupt if Block Mode is not used. Block Mode allows transfers of up to 64 KB per interrupt. Select

Disabled to allow data to be transferred from and to the device one sector at a time. Select Auto to allow data transfer from and to the device occur multiple sectors at a time if the device supports it. The options are **Auto** and Disabled.

### **PIO Mode**

The IDE PIO (Programmable I/O) Mode programs timing cycles between the IDE drive and the programmable IDE controller. As the PIO mode increases, the cycle time decreases. The options are **Auto**, 0, 1, 2, 3, and 4.

Select Auto to allow the AMI BIOS to automatically detect the PIO mode. Use this value if the IDE disk drive support cannot be determined.

Select 0 to allow the AMI BIOS to use PIO mode 0. It has a data transfer rate of 3.3 MB/s.

Select 1 to allow the AMI BIOS to use PIO mode 1. It has a data transfer rate of 5.2 MB/s.

Select 2 to allow the AMI BIOS to use PIO mode 2. It has a data transfer rate of 8.3 MB/s.

Select 3 to allow the AMI BIOS to use PIO mode 3. It has a data transfer rate of 11.1 MB/s.

Select 4 to allow the AMI BIOS to use PIO mode 4. It has a data transfer bandwidth of 32-Bits. Select Enabled to enable 32-Bit data transfer.

### **DMA Mode**

Select Auto to allow the BIOS to automatically detect IDE DMA mode when the IDE disk drive support cannot be determined.

Select SWDMA0 to allow the BIOS to use Single Word DMA mode 0. It has a data transfer rate of 2.1 MB/s.

Select SWDMA1 to allow the BIOS to use Single Word DMA mode 1. It has a data transfer rate of 4.2 MB/s.

Select SWDMA2 to allow the BIOS to use Single Word DMA mode 2. It has a data transfer rate of 8.3 MB/s.

Select MWDMA0 to allow the BIOS to use Multi Word DMA mode 0. It has a data transfer rate of 4.2 MB/s.

Select MWDMA1 to allow the BIOS to use Multi Word DMA mode 1. It has a data transfer rate of 13.3 MB/s.

Select MWDMA2 to allow the BIOS to use Multi-Word DMA mode 2. It has a data transfer rate of 16.6 MB/s.

Select UDMA0 to allow the BIOS to use Ultra DMA mode 0. It has a data transfer rate of 16.6 MB/s. It has the same transfer rate as PIO mode 4 and Multi Word DMA mode 2.

Select UDMA1 to allow the BIOS to use Ultra DMA mode 1. It has a data transfer rate of 25 MB/s.

Select UDMA2 to allow the BIOS to use Ultra DMA mode 2. It has a data transfer rate of 33.3 MB/s.

Select UDMA3 to allow the BIOS to use Ultra DMA mode 3. It has a data transfer rate of 44.4 MB/s.

Select UDMA4 to allow the BIOS to use Ultra DMA mode 4 . It has a data transfer rate of 66.7 MB/s.

Select UDMA5 to allow the BIOS to use Ultra DMA mode 5 . It has a data transfer rate of 100.0 MB/s.

Select UDMA6 to allow the BIOS to use Ultra DMA mode 6 . It has a data transfer rate of 133 MB/s.

The options are **Auto**, SWDMAn, MWDMAAn, and UDMAAn.

#### **S.M.A.R.T.**

Self-Monitoring Analysis and Reporting Technology (SMART) can help predict impending drive failures. Select Auto to allow the AMI BIOS to automatically detect hard disk drive support. Select Disabled to prevent the AMI BIOS from using the S.M.A.R.T. Select Enabled to allow the AMI BIOS to use the S.M.A.R.T. to support hard drive disk. The options are Disabled, Enabled, and **Auto**.

#### **32-Bit Data Transfer**

Select Enable to enable the function of 32-bit IDE data transfer. The options are **Enabled** and Disabled.

### **► PCI/PnP Configuration**

This feature allows the user to set the PCI/PnP configurations for the following items:

#### **Clear NVRAM**

This feature clears the NVRAM during system boot. The options are **No** and Yes.

#### **Plug & Play OS**

Selecting Yes allows the OS to configure Plug & Play devices. (This is not required for system boot if your system has an OS that supports Plug & Play.) Select **No** to allow the AMI BIOS to configure all devices in the system.

**PCI Latency Timer**

This feature sets the latency Timer of each PCI device installed on a PCI bus. Select 64 to set the PCI latency to 64 PCI clock cycles. The options are 32, **64**, 96, 128, 160, 192, 224 and 248.

**PCIX Slot Frequency**

This feature selects the maximum PCI bus speed. When Auto is selected, the bus speed is determined automatically by the system based on the capability of the device attached to the bus. The options are **Auto**, 33MHz PCI, 66MHz PCI, 66MHz PCI-X M1, 100MHz PCI-X M1, and 133MHz PCI-X M1.

**PCI IDE Bus Master**

When enabled, the BIOS uses PCI bus mastering for reading/writing to IDE drives. The options are Disabled and **Enabled**.

**PCIE I/O Performance**

This feature selects the setting for the IOH PCIE maximum payload size. The options are **128B** and 256B.

**ROM Scan Ordering**

This item determines what kind of option ROM activates over another. The options are **Onboard First** and Add-on First.

**Slot1 PCIX 133MHz, Slot2 PCIX 133MHz, Slot3 PCI 33MHz, Slot4 PCIE x16, Slot5 PCIE x4 on x8, Slot6 PCIE x16**

Use this feature to enable or disable a PCI-E, PCI-X or a PCI slot. The options are Disabled and **Enabled**.

**Load Onboard LAN1 Option ROM/Load Onboard LAN2 Option ROM**

This feature is to enable LAN OPROM for PXE. This is to boot computers using a network interface. The options are **Disabled** and Enabled.

**Boot Graphics Adapter Priority**

Use this feature to select the graphics controller to be used as the primary boot device. The options are Other and **Slot 6**. Select Slot 6 if a graphics controller is installed in the CPU-controlled Slot 6 slot.

**► Super IO Device Configuration****Serial Port1 Address/ Serial Port2 Address**

This option specifies the base I/O port address and the Interrupt Request address of Serial Port 1 and Serial Port 2. Select Disabled to prevent the serial port from

accessing any system resources. When this option is set to Disabled, the serial port physically becomes unavailable. Select 3F8/IRQ4 to allow the serial port to use 3F8 as its I/O port address and IRQ 4 for the interrupt address. The options for Serial Port1 are Disabled, **3F8/IRQ4**, 3E8/IRQ4, and 2E8/IRQ3. The options for Serial Port2 are Disabled, **2F8/IRQ3**, 3E8/IRQ4, and 2E8/IRQ3.

### **Serial Port 2 Mode**

Use this feature to configure Serial Port 2 mode. The options are **Normal**, IrDA and ASK IR. IrDA (Infrared Data) is an industry standard for remote control devices. ASK IR (Amplitude Shifted Keying Infrared) is a protocol compatible with Sharp® branded PDAs and other infrared devices.

### **Onboard Floppy Controller**

Select Enabled to enable the onboard Floppy Controller. The options are **Enabled** and Disabled.

## **► Remote Access Configuration**

### **Remote Access**

This allows the user to enable the Remote Access feature. The options are **Disabled** and Enabled.

If Remote Access is set to Enabled, the following items will display:

### **Serial Port Number**

This feature allows the user decide which serial port to be used for Console Redirection. The options are **COM 1 (Base Address 3F8h, IRQ 4)**, COM 2 (Base Address 2F8h, IRQ 3).

### **Serial Port Mode**

This feature allows the user to set the serial port mode for Console Redirection. The options are **115200 8, n 1**; 57600 8, n, 1; 38400 8, n, 1; 19200 8, n, 1; and 9600 8, n, 1.

### **Flow Control**

This feature allows the user to set the flow control for Console Redirection. The options are **None**, Hardware, and Software.

### **Redirection After BIOS POST**

Select Disabled to turn off Console Redirection after Power-On Self-Test (POST). Select Always to keep Console Redirection active all the time after POST. (Note: This setting may not be supported by some operating systems.)

---

Select Boot Loader to keep Console Redirection active during POST and Boot Loader. The options are Disabled, Boot Loader, and **Always**.

### Terminal Type

This feature allows the user to select the target terminal type for Console Redirection. The options are ANSI, **VT100**, and VT-UTF8.

### VT-UTF8 Combo Key Support

A terminal keyboard definition that provides a way to send commands from a remote console. Available options are **Enabled** and Disabled.

### Sredir Memory Display Delay

This feature defines the length of time in seconds to display memory information. The options are **No Delay**, Delay 1 Sec, Delay 2 Sec, and Delay 4 Sec.

## ► Hardware Health Configuration

This feature allows the user to monitor Hardware Health of the system and review the status of each item when displayed.

### CPU Overheat Alarm

This option allows the user to select the CPU Overheat Alarm setting which determines when the CPU OH alarm will be activated to provide warning of possible CPU overheat.



**Warning:** Any temperature that exceeds the CPU threshold temperature predefined by the CPU manufacturer may result in CPU overheat or system instability. When the CPU temperature reaches this predefined threshold, the CPU and system cooling fans will run at full speed.

The options are:

- The Early Alarm: Select this setting if you want the CPU overheat alarm (including the LED and the buzzer) to be triggered as soon as the CPU temperature reaches the CPU overheat threshold as predefined by the CPU manufacturer.
- **The Default Alarm:** Select this setting if you want the CPU overheat alarm (including the LED and the buzzer) to be triggered when the CPU temperature reaches about 5°C above the threshold temperature as predefined by the CPU manufacturer to give the CPU and system fans additional time needed for CPU and system cooling. In both the alarms above, please take immediate action as shown below. (See the notes on P. 4-18 for more information.)

## CPU Temperature/System Temperature

This feature displays current temperature readings for the CPU and the System.

The following items will be displayed for your reference only:

### CPU Temperature

The CPU Temperature feature will display the CPU temperature status as detected by the BIOS:

**Low** – This level is considered as the 'normal' operating state. The CPU temperature is well below the CPU 'Temperature Tolerance'. The motherboard fans and CPU will run normally as configured in the BIOS (Fan Speed Control).

User intervention: No action required.

**Medium** – The processor is running warmer. This is a 'precautionary' level and generally means that there may be factors contributing to this condition, but the CPU is still within its normal operating state and below the CPU 'Temperature Tolerance'. The motherboard fans and CPU will run normally as configured in the BIOS. The fans may adjust to a faster speed depending on the Fan Speed Control settings.

User intervention: No action is required. However, consider checking the CPU fans and the chassis ventilation for blockage.

**High** – The processor is running hot. This is a 'caution' level since the CPU's 'Temperature Tolerance' has been reached (or has been exceeded) and may activate an overheat alarm:

The Default Alarm – the Overheat LED and system buzzer will activate if the High condition continues for some time after it is reached. The CPU fan will run at full speed to bring the CPU temperature down. If the CPU temperature still increases even with the CPU fan running at full speed, the system buzzer will activate and the Overheat LED will turn on.

The Early Alarm – the Overheat LED and system buzzer will be activated exactly when the High level is reached. The CPU fan will run at full speed to bring the CPU temperature down.

Note: In both the alarms above, please take immediate action as shown below. See CPU Overheat Alarm to modify the above alarm settings.

User intervention: If the system buzzer and Overheat LED has activated, take action immediately by checking the system fans, chassis ventilation and room temperature to correct any problems. Note: the system may shut down if it continues for a long period to prevent damage to the CPU.



**Notes:** The CPU thermal technology that reports absolute temperatures (Celsius/Fahrenheit) has been upgraded to a more advanced feature by Intel

in its newer processors. The basic concept is that each CPU is embedded by a unique temperature information that the motherboard can read. This 'Temperature Threshold' or 'Temperature Tolerance' has been assigned at the factory and is the baseline by which the motherboard takes action during different CPU temperature conditions (i.e., by increasing CPU Fan speed, triggering the Overheat Alarm, etc). Since CPUs can have different 'Temperature Tolerances', the installed CPU can now send its 'Temperature Tolerance' to the motherboard resulting in better CPU thermal management.

Supermicro has leveraged this feature by assigning a temperature status to certain thermal conditions in the processor (Low, Medium and High). This makes it easier for the user to understand the CPU's temperature status, rather than by just simply seeing a temperature reading (i.e., 25°C).

The information provided above is for your reference only. For more information on thermal management, please refer to Intel's Web site at [www.Intel.com](http://www.Intel.com).

### **IOH Temperature**

This feature displays the absolute Input/Output Hub (IOH) temperature (i.e., 51°C).

### **System Temperature**

This feature displays the absolute system temperature (i.e., 34°C).

### **Fan1 ~ Fan 6 Reading**

This feature displays the fan speed readings from fan interfaces Fan1 through Fan6.

### **Fan Speed Control Modes**

This feature allows the user to decide how the system controls the speeds of the onboard fans. The CPU temperature and the fan speed are correlative. When the CPU on-die temperature increases, the fan speed will also increase for effective system cooling. Select Full Speed to allow the onboard fans to run at full speed (of 100% Pulse Width Modulation Duty Cycle) for maximum cooling. The Full Speed setting is recommended for special system configuration or debugging. Select Performance for the onboard fans to run at 70% of the Initial PWM Cycle for better system cooling. The Performance setting is recommended for high-power-consuming and high-density systems. Select Balanced for the onboard fans to run at 50% of the Initial PWM Cycle in order to balance the needs between system cooling and power saving. The Balanced setting is recommended for regular systems with normal hardware configurations. Select Energy Saving for the onboard fans to run at 30% of the Initial PWM Cycle for best power efficiency and maximum quietness. The Options are: Full Speed/FS (@100% of PWM Cycle), Performance/PF (@70%

of PWM Cycle), **Balanced/BL** (@50% of PWM Cycle), and Energy Saving/ES (@30% of PWM Cycle).

### **Voltage Reading**

This feature displays the current voltage detected of the various components in the system:

Vcore, VDIMM, 5V, 12V, -12V, 3.3Vcc, 3.3VSB, VBAT, Vtt

### **►ACPI Configuration**

Use this feature to configure Advanced Configuration and Power Interface (ACPI) power management settings for your system.

### **High Performance Event Timer**

Select Enabled to activate the High Performance Event Timer (HPET) that produces periodic interrupts at a much higher frequency than a Real-time Clock (RTC) does in synchronizing multimedia streams, providing smooth playback and reducing the dependency on other timestamp calculation devices, such as an x86 RDTSC Instruction embedded in the CPU. The High Performance Event Timer is used to replace the 8254 Programmable Interval Timer. The options are **Enabled** and Disabled.

### **USB Device Wakeup from S3/S4**

This option is used to enable system wakeup through a USB device from suspend states S3/S4. The options are **Enabled** and Disabled.

### **ACPI Aware O/S**

Enable ACPI support if it is supported by the OS to control ACPI through the Operating System. Otherwise, disable this feature. The options are **Yes** and No.

### **Suspend Mode**

This option is used to select the ACPI State that is used for system suspend. The options are **S1 (POS)**, S3 (STR) and Auto.

S1 (POS) - All processor caches are erased, and stops executing instructions. Power to the CPU(s) and RAM is maintained, but RAM is refreshed.

S3 (STR) - The CPU has no power and the power supply goes on reduced power mode. However, main memory (RAM) is still powered.

### **AMI OEMB Table**

This enables the OEMB table support. The options are **Enabled** and Disabled.

**ACPI APIC Support**

Select Enabled to include the ACPI APIC Table Pointer in the RSDT (Root System Description Table) pointer list. The options are **Enabled** and Disabled.

**APIC ACPI SCI IRQ**

When this item is set to Enabled, APIC ACPI SCI IRQ is supported by the system. The options are Enabled and **Disabled**.

**Headless Mode**

This feature is used to enable system to function without a keyboard, monitor or mouse attached. The options are Enabled and **Disabled**.

**ACPI Version Features**

The options are ACPI v1.0, **ACPI v2.0** and ACPI v3.0. Please refer to ACPI's website for further explanation: <http://www.acpi.info/>

**► Event Log Configuration****View Event Log**

Use this option to view the System Event Log.

**Mark all events as read**

This option marks all events as read. The options are OK and Cancel.

**Clear event log**

This option clears the Event Log memory of all messages. The options are OK and **Cancel**.

**PCIe Error Log**

Use this option to enable logging of errors encountered in the system's PCIe bus. The options are Yes and **No**.

**Memory ECC Error Log**

Use this option to enable logging of errors encountered in the system's memory. The options are **Yes** and No.

## 4-4 Security Settings

The AMI BIOS provides a Supervisor and a User password. If you use both passwords, the Supervisor password must be set first.

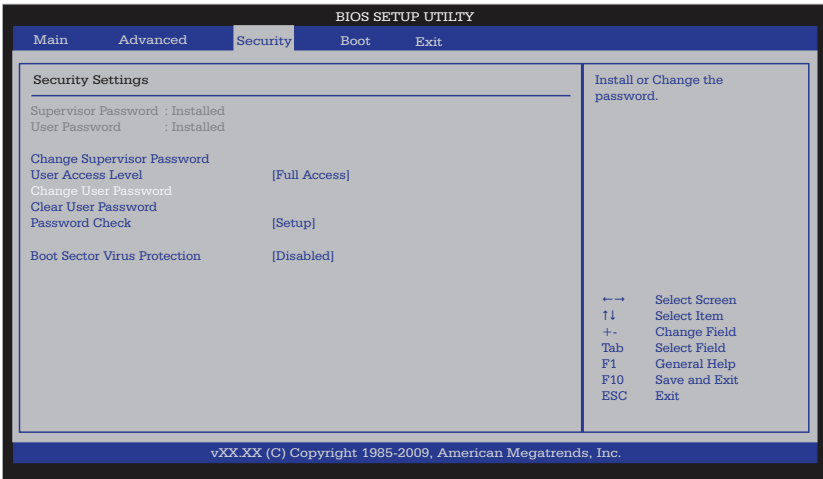

### Supervisor Password

This item indicates if a supervisor password has been entered for the system. Clear means such a password has not been used and Set means a supervisor password has been entered for the system.

### User Password:

This item indicates if a user password has been entered for the system. Clear means such a password has not been used and Set means a user password has been entered for the system.

### Change Supervisor Password

Select this feature and press <Enter> to access the submenu, and then type in a new Supervisor Password.

### User Access Level (Available when Supervisor Password is set as above)

Available options are **Full Access**: grants full User read and write access to the Setup Utility, **View Only**: allows access to the Setup Utility but the fields cannot be changed, **Limited**: allows only limited fields to be changed such as Date and Time, **No Access**: prevents User access to the Setup Utility.

### Change User Password

Select this feature and press <Enter> to access the submenu , and then type in a new User Password.

**Clear User Password (Available only if User Password has been set)****Password Check**

Available options are **Setup** and Always.

**Boot Sector Virus Protection**

When Enabled, the AMI BOIS displays a warning when any program (or virus) issues a Disk Format command or attempts to write to the boot sector of the hard disk drive. The options are Enabled and **Disabled**.

## 4-5 Boot Configuration

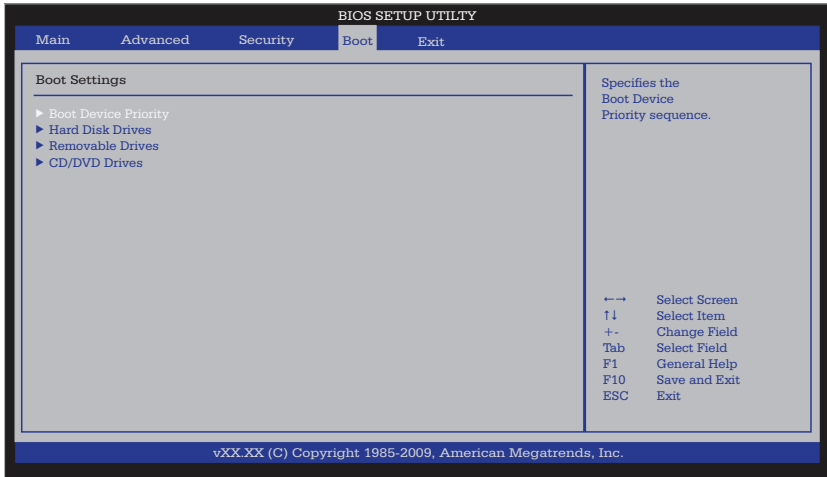

Use this feature to configure Boot Settings:

**▶ Boot Device Priority**

This feature allows the user to specify the sequence of priority for the Boot Device. The settings are 1st boot device, 2nd boot device, 3rd boot device, 4th boot device, 5th boot device and Disabled.

- 1st Boot Device - 1st Floppy Drive
- 2nd Boot Device - [USB: XXXXXXXXXXXX]
- 3rd Boot Device - [SATA: XXXXXXXXXXXX]
- 4th Boot Device - [Network: XXXXXXXXXXXX]
- 5th Boot Device - [Network: XXXXXXXXXXXX]

## ► Hard Disk Drives

This feature allows the user to specify the boot sequence from all available hard disk drives. The settings are Disabled and a list of all hard disk drives that have been detected (i.e., 1st Drive, 2nd Drive, 3rd Drive, etc).

## ► Removable Drives

This feature allows the user to specify the boot sequence from available Removable Drives. The settings are 1st boot device, 2nd boot device, and Disabled.

- 1st Drive
- 2nd Drive - [USB: XXXXXXXXX]

## ► CD/DVD Drives

This feature allows the user to specify the boot sequence from available CD/DVD Drives (i.e., 1st Drive, 2nd Drive, etc).

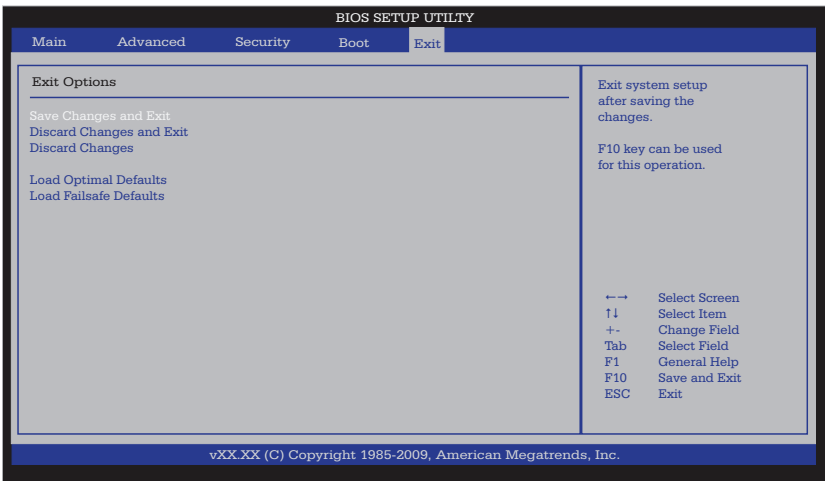

## 4-6 Exit Options

Select the Exit tab from the AMI BIOS Setup Utility screen to enter the Exit BIOS Setup screen.

### Save Changes and Exit

When you have completed the system configuration changes, select this option to leave the BIOS Setup Utility and reboot the computer, so the new system con-

figuration parameters can take effect. Select Save Changes and Exit from the Exit menu and press <Enter>.

**Discard Changes and Exit**

Select this option to quit the BIOS Setup without making any permanent changes to the system configuration, and reboot the computer. Select Discard Changes and Exit from the Exit menu and press <Enter>.

**Discard Changes**

Select this option and press <Enter> to discard all the changes and return to the AMI BIOS Utility Program.

**Load Optimal Defaults**

To set this feature, select Load Optimal Defaults from the Exit menu and press <Enter>. Then, select OK to allow the AMI BIOS to automatically load Optimal Defaults to the BIOS Settings. The Optimal settings are designed for maximum system performance, but may not work best for all computer applications.

**Load Fail-Safe Defaults**

To set this feature, select Load Fail-Safe Defaults from the Exit menu and press <Enter>. The Fail-Safe settings are designed for maximum system stability, but not for maximum performance.

## Notes

## Appendix A

### POST Error Beep Codes

This section lists POST (Power On Self Test) error beep codes for the AMI BIOS. POST error beep codes are divided into two categories: recoverable and terminal. This section lists Beep Codes for recoverable POST errors.

#### Recoverable POST Error Beep Codes

When a recoverable type of error occurs during POST, BIOS will display a POST code that describes the problem. BIOS may also issue one of the following beep codes:

- 1 long and two short beeps - video configuration error
- 1 repetitive long beep - no memory detected
- 1 continuous beep with the front panel Overheat LED on - system overheat
- 8 beeps - memory error

## Notes

## Appendix B

### Software Installation Instructions

#### B-1 Installing Drivers

After you've installed the Windows Operating System, a screen as shown below will appear. You are ready to install software programs and drivers that have not yet been installed. To install these software programs and drivers, click the icons to the right of these items. (Note: To install the Windows OS, please refer to the Windows OS Installation Guide posted at [http://www.supermicro.com/support/manuals/.](http://www.supermicro.com/support/manuals/))

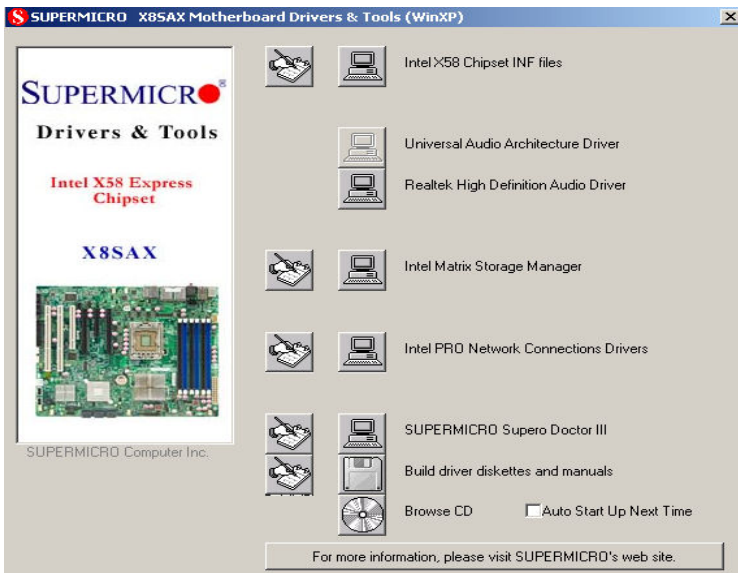

**Driver/Tool Installation Display Screen**



**Note :** Click the icons showing a hand writing on the paper to view the readme files for each item. Click a computer icon to the right of an item (from top to the bottom) one at a time. After installing each item, you must re-boot the system before proceeding with the next item on the list. The bottom icon with a CD on it allows you to view the entire contents of the CD.

## B-2 Configuring SuperDoctor<sup>®</sup> III

The SuperDoctor III program is a Web-based management tool that supports remote management capability. It includes Remote and Local Management tools. The local management tool is called the SD III Client. The SuperDoctor III program included on the CDROM that came with your motherboard allows you to monitor the environment and operations of your system. SuperDoctor III displays crucial system information such as CPU temperature, system voltages and fan status. See the Figure below for a display of the SuperDoctor III interface.



**Note:** 1 The default user name and password are ADMIN.

**Note 2:** In the Windows OS environment, the SuperDoctor III settings take precedence over the BIOS settings. When first installed, SuperDoctor III adopts the temperature threshold settings previously set in BIOS. Any subsequent changes to these thresholds must be made within SuperDoctor, since the settings override the BIOS settings. For the Windows OS to adopt the BIOS temperature threshold settings, please change the SD III Client settings to be the same as those set in BIOS.

SuperDoctor III Interface Display Screen-I (Health Information)

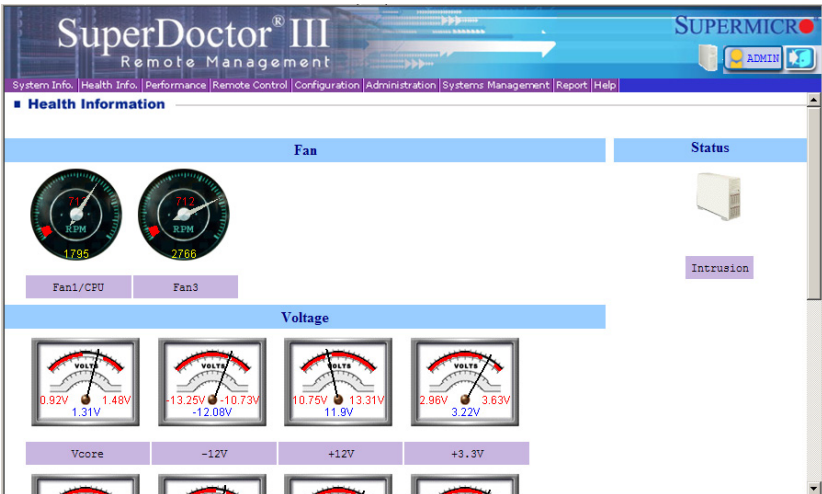

## SuperDoctor III Interface Display Screen-II (Remote Control)



**Graceful power control (cancelable)**

Super Doctor III allows a user to inform the OS to reboot or shut down the system within 30 seconds. On the system console, a pop-up window will appear with a message telling the local user to save his working files. Before the system reboots or shuts down, it's allowed to cancel the action either locally or remotely.

**Power control (noncancelable)**

Super Doctor III allows a user to inform the OS to reboot or shut down the system right away. The system will reboot or shut down without any warning messages. It's not allowed to cancel the action.



**Note:** The SuperDoctor III software and manual may be downloaded from our Website at:

<http://www.supermicro.com/products/accessories/software/SuperDoctorIII.cfm>.

For Linux, we still recommend that you use SuperDoctor II, this version is also available for download at the link above.

## Notes

---

---

## Appendix C - BIOS Recovery

The recovery procedure described in this section is to be used only when advised by your Supermicro Technical Support representative, or in cases of emergencies where the system no longer can boot due to a corrupted BIOS. DO NOT re-program (re-flash) the BIOS if your system is running properly.

### C-1 Recovery Process from a USB Device/Drive (Recommended Method)

If the BIOS file is corrupted and the system is not able to boot up, this feature will allow you to recover the BIOS image using a USB-attached device. A USB Flash Drive or a USB CD/DVD ROM/RW drive may be used for this purpose. Please note that a USB Hard Disk drive is NOT supported at this time. Below is a two-part procedure to recover the BIOS:

#### Part 1: Boot Sector Recovery Process

1. Using a different system, download and copy the correct BIOS binary image into a USB flash device or a writable CD/DVD disc's Root "" Directory. Rename the downloaded file to "super.rom", so the recovery process can recognize and read the BIOS binary file.
2. Insert the USB device that contains the new BIOS binary image ("super.rom") and power the system down.
3. While powering on the system, press and hold <Ctrl> and <Home> simultaneously on your keyboard until the USB device's LED indicator comes on. This will take a few seconds or up to one minute.
4. Once the USB device's LED is on, release the <Ctrl> and <Home> keys. The system may generate beep codes to indicate that the BIOS ROM firmware is being reprogrammed. The screen will also display a message as shown below. DO NOT INTERRUPT THIS PROCESS!

```
Starting FLASH Recovery.  
NVRAM data will be destroyed.  
CMOS data will be destroyed.  
.....  
.....  
Ending FLASH Recovery.  
FLASH Update completed successfully.  
Rebooting...
```

5. When the Boot Sector Recovery Process is complete, the system will reboot automatically and you will see a checksum error on your screen.

## Part 2 - BIOS Reprogramming (Re-Flashing)

After completing the Boot Sector Recovery Process, you will need to reprogram ("re-flash") the proper BIOS binary file again into the BIOS ROM in order to have the correct BIOS file loaded by the system. For details on how to flash/re-flash a BIOS, please check our website for "Update your BIOS", or see the section 3-3 (FAQ) of this manual. **DO NOT INTERRUPT THIS PROCESS!**

When completed, the system will reboot automatically, and you will see a checksum error again.

Press "F1" to go to setup. Press "F9" to load the defaults and then press "F10" to save and exit.

## C-2 Recovery Process from an IDE/SATA ATAPI Disc Drive

This process is identical to the Boot Sector Recovery Process from a USB Device/Drive (as above), except that the BIOS image file ("super.rom") is loaded from an IDE/ATAPI CD/DVD-ROM/RW disc drive that is attached to the system. Note that loading from an IDE/SATA hard disk drive is NOT supported.

1. Using a different system, download and copy the correct BIOS binary image into a writable CD/DVD disc's Root "\" Directory. Rename the downloaded file to "super.rom", so the recovery process can recognize and read the BIOS binary file.



**Note:** Record/Burn the CD/DVD-R/RW disc using the ISO 9600 standard format. Refer to your CD/DVD mastering application documentation for instructions on how to do this.

2. Insert the newly-created disc into the IDE/SATA ATAPI CD/DVD ROM/RW drive of the system that has the corrupted BIOS and power the system down.
3. Follow the step-by-step instructions under Part 1 - Recovery Process from a USB Device/Drive (above) starting from Step 3 and continue on to Part 2 - BIOS Reprogramming (Re-Flashing).

If your system still does not boot up after performing the above procedure, then there may be other issues with your motherboard. Please contact your customer service representative.

(Disclaimer)

The products sold by Supermicro are not intended for and will not be used in life support systems, medical equipment, nuclear facilities or systems, aircraft, aircraft devices, aircraft/emergency communication devices or other critical systems whose failure to perform be reasonably expected to result in significant injury or loss of life or catastrophic property damage. Accordingly, Supermicro disclaims any and all liability, and should buyer use or sell such products for use in such ultra-hazardous applications, it does so entirely at its own risk. Furthermore, buyer agrees to fully indemnify, defend and hold Supermicro harmless for and against any and all claims, demands, actions, litigation, and proceedings of any kind arising out of or related to such ultra-hazardous use or sale.